

5665

23796

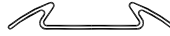

1:1

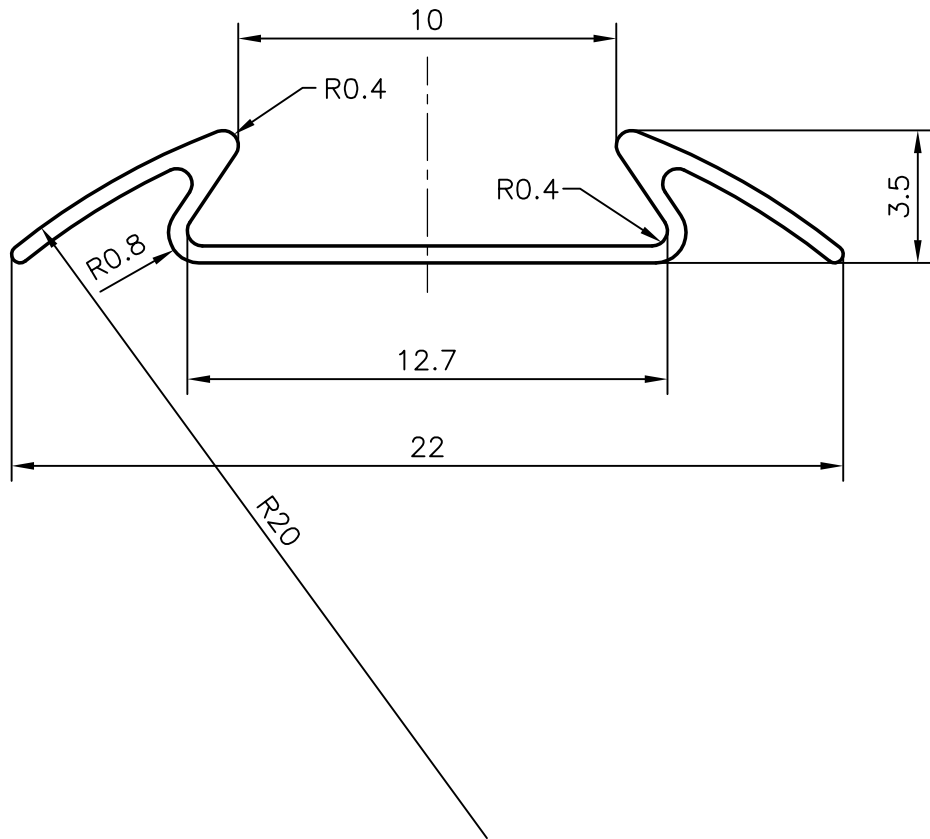

1. GENERAL WALL THICKNESS:- 0.45 mm.
2. NO. OF PIECES IN 100 kgs.:- 650 (AVERAGE)

JINDAL ALUMINIUM LTD.

BANGALORE-560073

NAME

DATE

DRAWN

R.D.Sharma

19-07-97

1. ALL DIMENSIONS ARE IN mm.
2. ROUND OFF ALL SHARP CORNERS WITH 0.4 mm.
3. TOLERANCES WILL BE AS PER IS: 3965-1981 ,UNLESS OTHERWISE SPECIFIED

CHECKED

APPROVED

PARTY'S NAME

-

SCALE

5:1

PARTY'S DRAWING No.

-

WEIGHT kg/m

0.042

ALLOY & TEMPER

HE9 WP

SECTION No.

23796

LENGTH

3658 mm.

DRAWING No.

DESCRIPTION

SINGLE BEADING

23796