

5666

23797

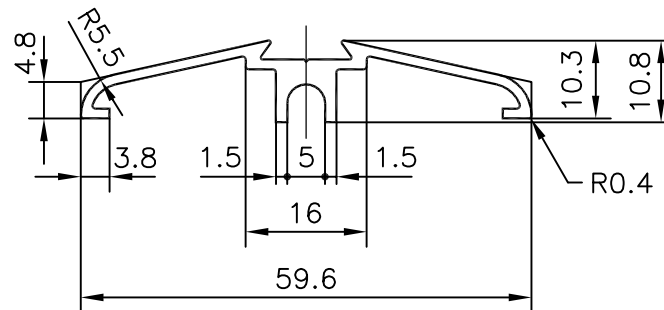
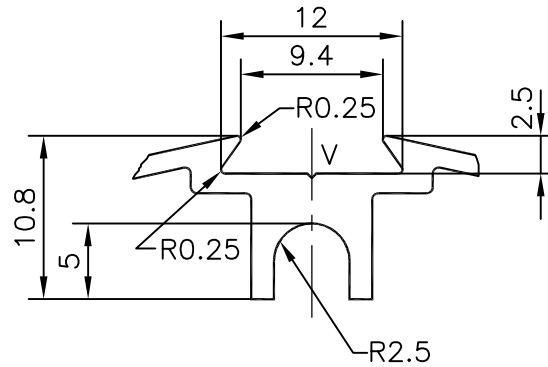

1. GENERAL WALL THICKNESS:- 1.30 mm.
2. $V = 0.3 \times 90^\circ$ V GROOVE

JINDAL ALUMINIUM LTD.

BANGALORE-560073

JINDAL ALUMINIUM LTD. BANGALORE-560073		NAME		DATE
		DRAWN		R.D.Sharma
1. ALL DIMENSIONS ARE IN mm. 2. ROUND OFF ALL SHARP CORNERS WITH 0.4 mm. 3. TOLERANCES WILL BE AS PER IS: 3965-1981 ,UNLESS OTHERWISE SPECIFIED		CHECKED		
		APPROVED		
PARTY'S NAME	A.ABDUL RAHIM OOSMAN & CO.,MAURITIUS	SCALE		1:1 & 2:1
PARTY'S DRAWING No.	AS PER SAMPLE	WEIGHT kg/m		0.368
ALLOY & TEMPER	HE9 WP (6063 T6)	SECTION No.		23797
LENGTH	5500 mm.	DRAWING No.		
DESCRIPTION	SHOW BEADING	23797		