

5669

23800

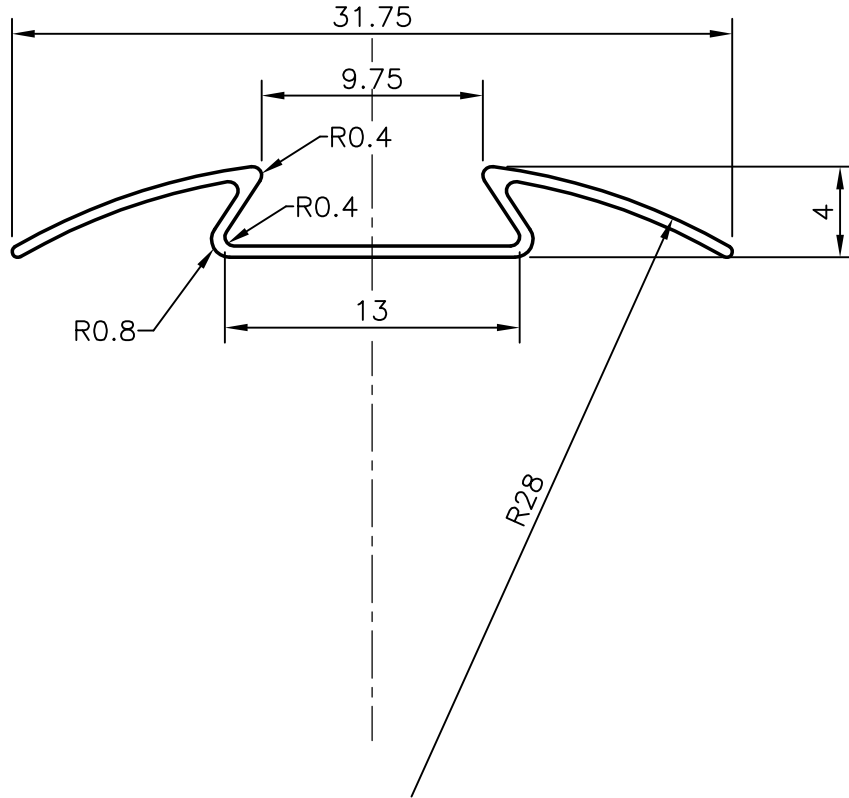

1:1



GENERAL WALL THICKNESS :- 0.50 mm.

NO. OF PIECES IN 100 kgs:- 450 (AVERAGE)

**JINDAL ALUMINIUM LTD.****BANGALORE-560073**

NAME

DATE

DRAWN

R.D.Sharma

27-02-98

CHECKED

APPROVED

1. ALL DIMENSIONS ARE IN mm.  
 2. ROUND OFF ALL SHARP CORNERS WITH 0.4 mm.  
 3. TOLERANCES WILL BE AS PER IS: 3965-1981 ,UNLESS OTHERWISE SPECIFIED

PARTY'S NAME

GENERAL CATEGORY

SCALE

3:1

PARTY'S DRAWING No.

NIL

WEIGHT kg/m

0.060

ALLOY &amp; TEMPER

HE9 WP

SECTION No.

23800

LENGTH

3658 mm.

DRAWING No.

DESCRIPTION

BEADING SECTION

23800