

5674

23805

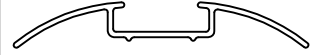

SCALE 1:1

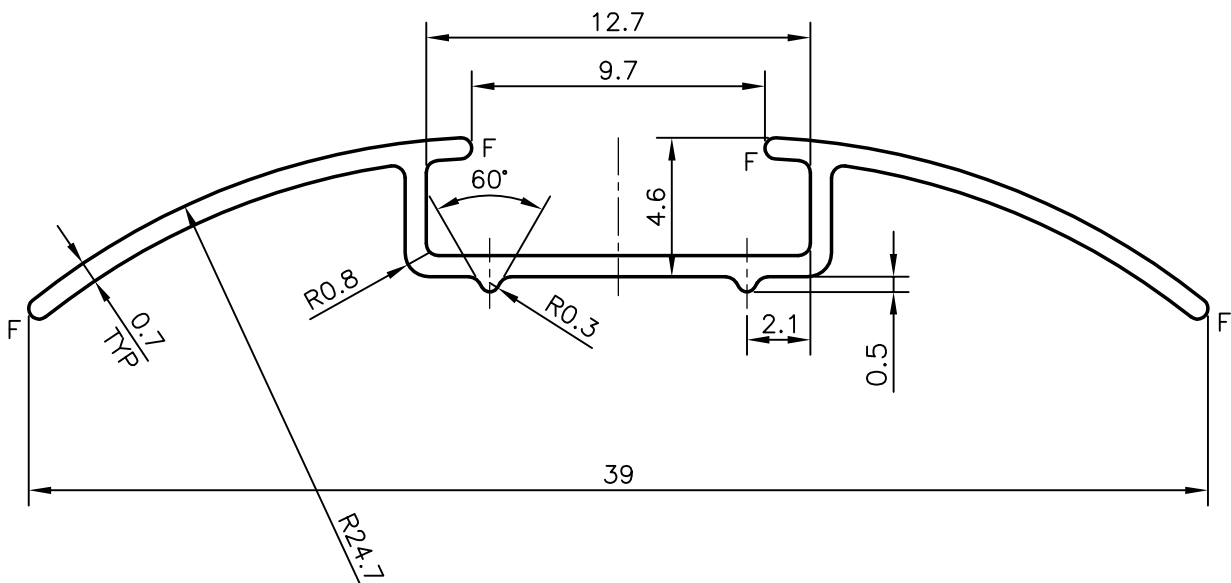

GENERAL WALL THICKNESS = 0.70mm

F = FULL RADII (4 PLACE)

NO. OF PIECES IN 100kgs = 275 (AVERAGE)



SYMBOL OF QUALITY
AN ISO 9001 COMPANY

JINDAL ALUMINIUM LTD.
BANGALORE-560073 (INDIA)

	NAME	DATE
DRAWN	RAGHAVENDRA	05-03-2007
CHECKED		
APPROVED		

1. ALL DIMENSIONS ARE IN mm.
2. ROUND OFF ALL SHARP CORNERS WITH 0.40 mm.
3. TOLERANCES WILL BE AS PER IS:3965-1981 UNLESS OTHERWISE SPECIFIED

SCALE	4:1
AREA mm ²	36.77
PERIMETER mm.	103.216
WEIGHT kg/m	0.0993

PARTY'S NAME	-	DRAWING No.	5674	SECTION No.	5674
PARTY'S DRAWING No.	LIGHTER SECTION OF 5619	23805	23805		
ALLOY & TEMPER	HE9 WP				
DESCRIPTION	SINGLE BEADING				