

P-5771-1
23811

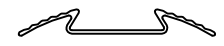

SCALE 1:1

3658mm LONG PIECES IN 100kgs = 650 (AVERAGE)
F = FULL RADII (2 PLACES)

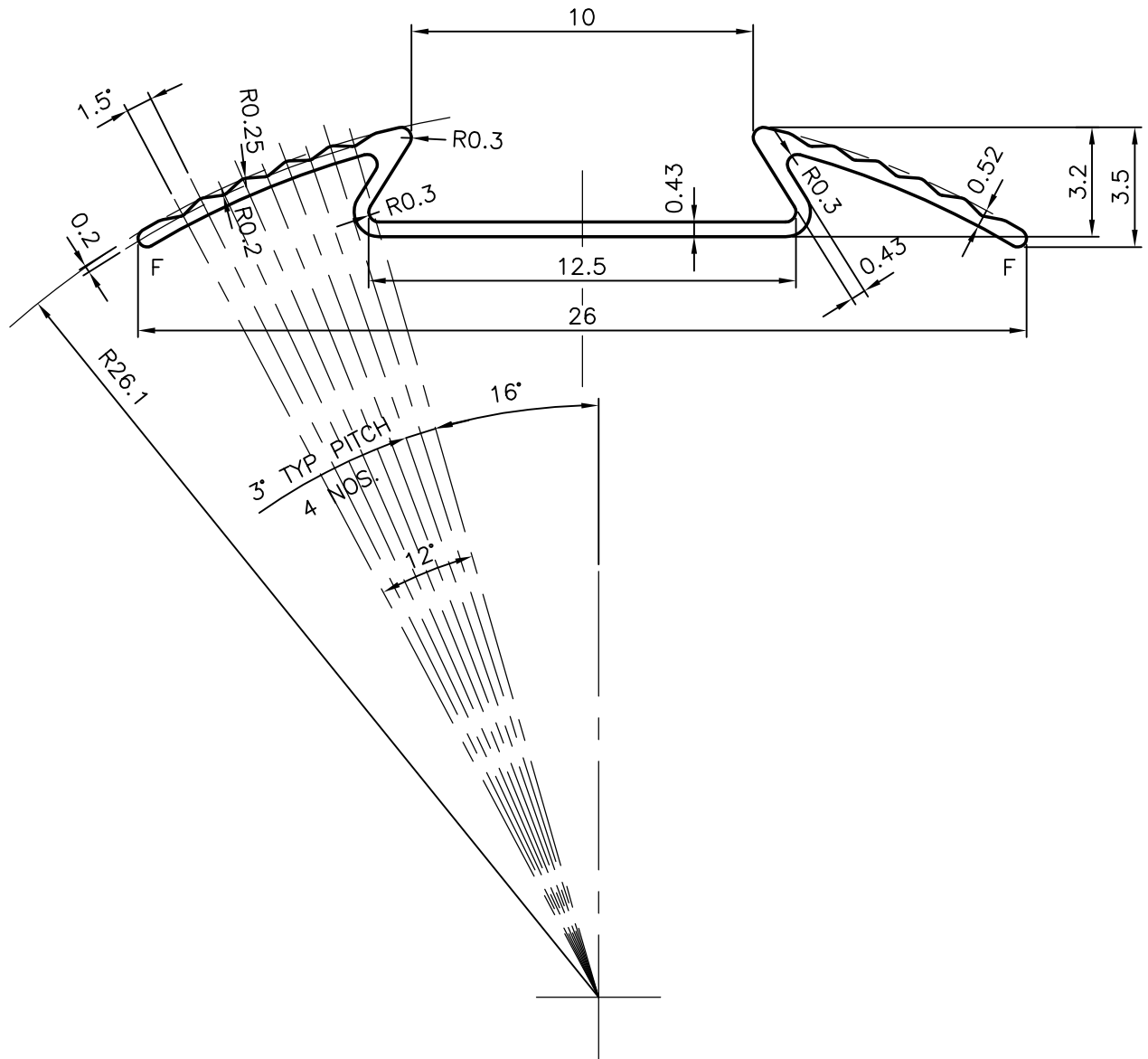

SYMBOL OF QUALITY
AN ISO 9001 COMPANY

JINDAL ALUMINIUM LTD.
BANGALORE-560073 (INDIA)

	NAME	DATE
DRAWN	MALINGAPPA	22-08-2005
CHECKED		
APPROVED		

1. ALL DIMENSIONS ARE IN mm.
2. ROUND OFF ALL SHARP CORNERS WITH 0.40 mm.
3. TOLERANCES WILL BE AS PER IS:3965-1981 UNLESS OTHERWISE SPECIFIED

SCALE	5:1
AREA mm ²	15.458
PERIMETER mm.	69.39
WEIGHT kg/m	0.042

PARTY'S NAME	GENERAL CATEGORY, DELHI MARKET
PARTY'S DRAWING No.	AS PER SAMPLE/WEIGHT
ALLOY & TEMPER	HE9 WP
DESCRIPTION	SHOW BEADING SECTION

DRAWING No.	SECTION No.
P-5771-1	-
23811	23811