

P-13153

23817



SCALE 1:1

GENERAL WALL THICKNESS = 0.39mm

F = FULL RADIUS (6 PLACES)

3658mm LONG PIECES IN 100kgs = 506 (AVERAGE)

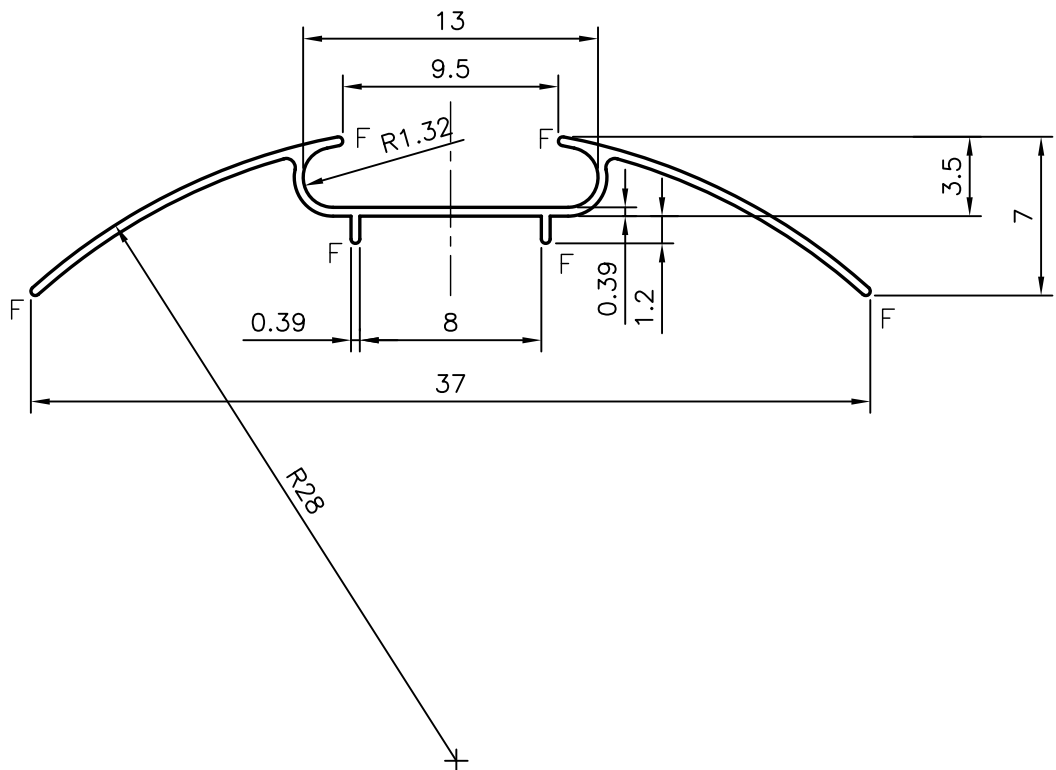

SYMBOL OF QUALITY
AN ISO 9001 COMPANY

JINDAL ALUMINIUM LTD.
BANGALORE-560073 (INDIA)

	NAME	DATE
DRAWN	RAGHAVENDRA	22-10-2013
CHECKED		
APPROVED	S.S.GARG	06-11-2013
SCALE		3:1
AREA mm ²		20.091
PERIMETER mm.		99.554
WEIGHT kg/m		0.054
DRAWING No.	SECTION No.	
P-13153	-	
23817	23817	

1. ALL DIMENSIONS ARE IN mm.
2. ROUND OFF ALL SHARP CORNERS WITH 0.40 mm.
3. TOLERANCES WILL BE AS PER IS:3965-1981 UNLESS OTHERWISE SPECIFIED

PARTY'S NAME	GENERAL CATEGORY, DELHI MARKET
PARTY'S DRAWING No.	LIGHTER OF SECTION NO. 23780
ALLOY & TEMPER	HE9 WP
DESCRIPTION	SHOW BEADING'S SECTION