

P-16127-2

23819

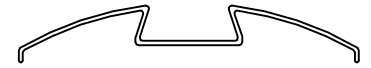

SCALE 1:1

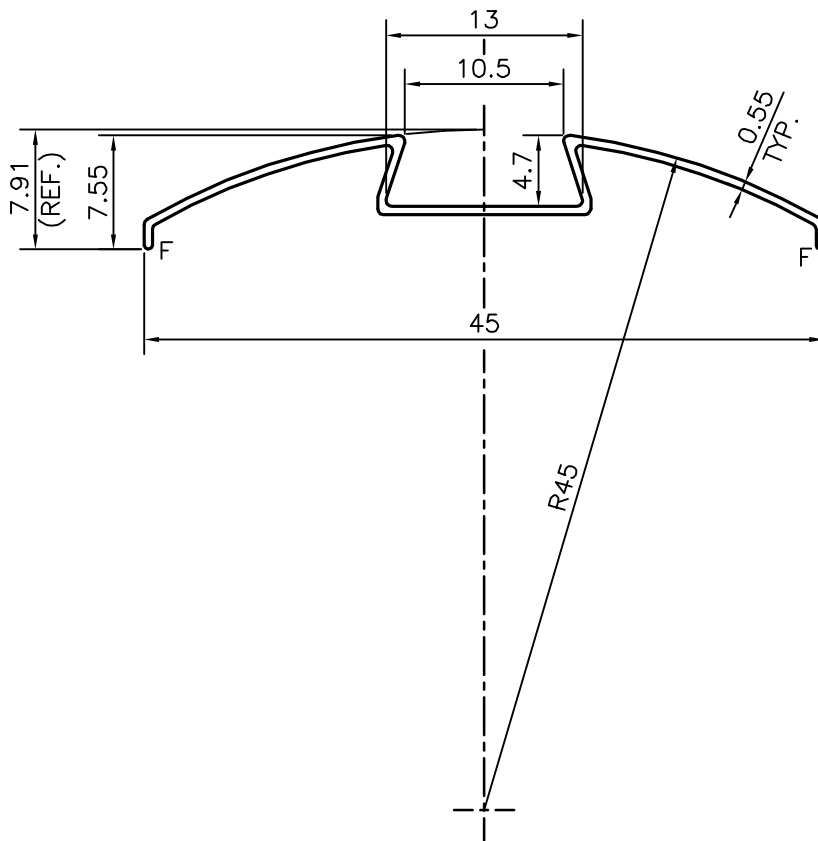

F = FULL RADIUS (2 PLACES)

PLEASE CONFIRM ALL THE DIMENSIONS AND MATCH WITH YOUR MATCHING COMPONENT

PLEASE SPECIFY THE EXPOSED SURFACE IN THE DRAWING WHEREVER BETTER FINISH REQUIRED.

 SYMBOL OF QUALITY AN ISO 9001 COMPANY	JINDAL ALUMINIUM LTD. BANGALORE-560073 (INDIA)	NAME	DATE
		DRAWN	KIRAN
		CHECKED	
		APPROVED	S.S. GARG
		SCALE	2:1
		AREA mm ²	34.270
		PERIMETER mm.	122.720
		WEIGHT kg/m	0.092
PARTY'S NAME	GENERAL CATEGORY, DELHI MARKET	DRAWING No.	SECTION No.
PARTY'S DRAWING No.	AS PER REQUIREMENT	P-16127-2	
ALLOY & TEMPER	HE9 WP	23819	23819
DESCRIPTION	BEADING SECTION		