

P-15179-1

S4827

23820

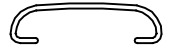

1:1

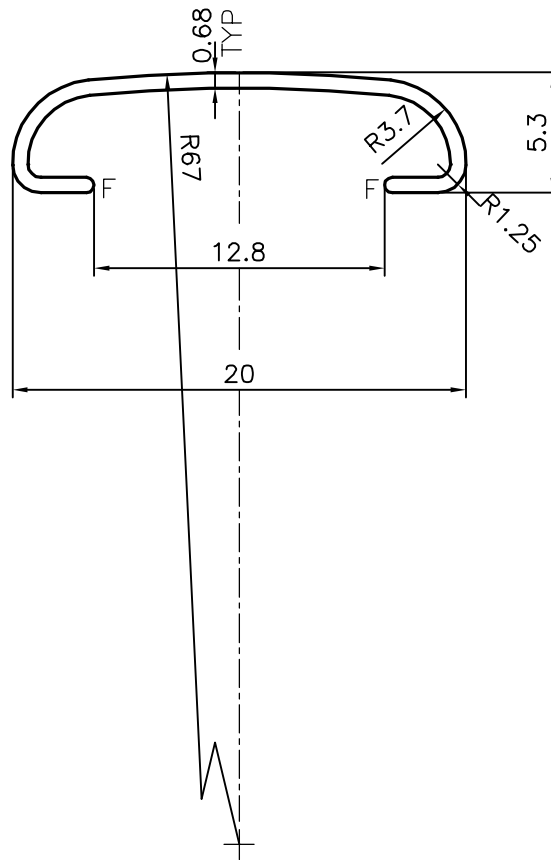

F= FULL RADIUS (2 PLACES)



SYMBOL OF QUALITY
AN ISO 9001 COMPANY

JINDAL ALUMINIUM LTD.
BANGALORE-560073 (INDIA)

	NAME	DATE
DRAWN	J.P.KAUSHIK	01-01-2016
CHECKED		
APPROVED	S.S.GARG	23-01-2016
SCALE		3:1
AREA mm ²		20.85
PERIMETER mm.		62.391
WEIGHT kg/m		0.056
DRAWING No.	SECTION No.	
P-15179-1	-	
S4827	S4827	
23820	23820	

1. ALL DIMENSIONS ARE IN mm.
2. ROUND OFF ALL SHARP CORNERS WITH 0.40 mm.
3. TOLERANCES WILL BE AS PER IS:3965-1981, UNLESS OTHERWISE SPECIFIED

PARTY'S NAME	SURESH INDUSTRIES, AGRA
PARTY'S DRAWING No.	AP-889
ALLOY & TEMPER	6063 T6
DESCRIPTION	BEADING SECTION