

6025

24020

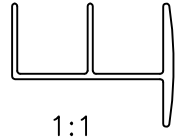

1:1

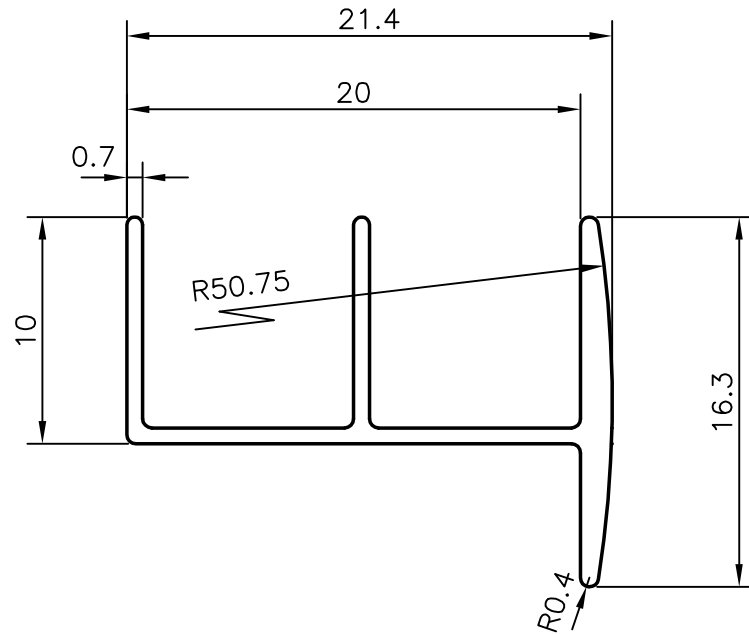

GENERAL WALL THICKNESS:- 0.70 mm.

JINDAL ALUMINIUM LTD.**BANGALORE-560073**

NAME

DATE

DRAWN

R.D.Sharma

7-9-96

1. ALL DIMENSIONS ARE IN mm.
2. ROUND OFF ALL SHARP CORNERS WITH 0.4 mm.
3. TOLERANCES WILL BE AS PER IS: 3965-1981 ,UNLESS OTHERWISE SPECIFIED

CHECKED

APPROVED

PARTY'S NAME

-

SCALE

3:1

PARTY'S DRAWING No.

-

WEIGHT kg/m

0.125

ALLOY & TEMPER

HE9 WP

SECTION No.

24020

LENGTH

3658 mm.

DRAWING No.

DESCRIPTION

DOOBLE GLASS CHANNEL-SPECIAL

24020