

6067

24215

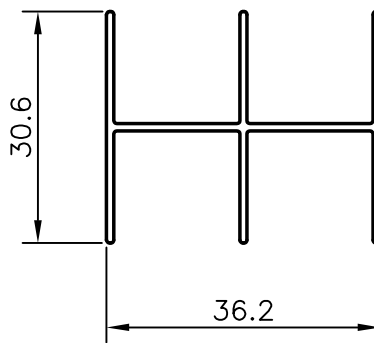

GENERAL WALL THICKNESS:- 0.97 mm.

WEIGHT OF 12' LONG PIECE:- 1.200 kgs (AVERAGE)

JINDAL ALUMINIUM LTD.**BANGALORE-560073**

JINDAL ALUMINIUM LTD. BANGALORE-560073		NAME	DATE
		DRAWN	R.D.Sharma
1. ALL DIMENSIONS ARE IN mm. 2. ROUND OFF ALL SHARP CORNERS WITH 0.4 mm. 3. TOLERANCES WILL BE AS PER IS: 3965-1981 ,UNLESS OTHERWISE SPECIFIED		CHECKED	
		APPROVED	
		SCALE	1:1
PARTY'S NAME	-	WEIGHT kg/m	0.328
PARTY'S DRAWING No.	NIL	SECTION No.	24215
ALLOY & TEMPER	HE9 WP	DRAWING No.	24215
LENGTH	3658 mm.		
DESCRIPTION	DOUBLE H SECTION		