

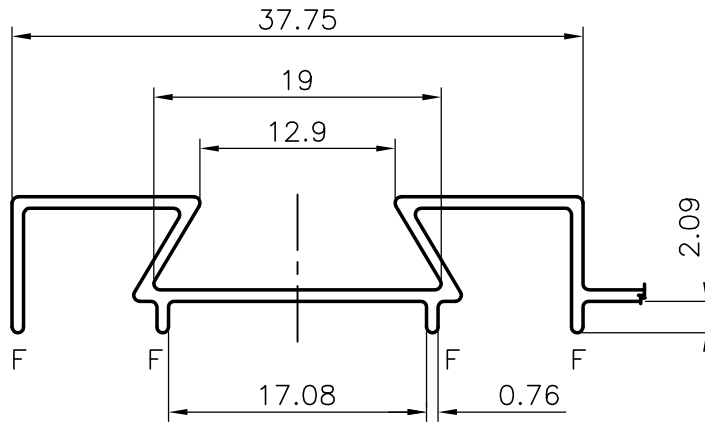

P-4600
6552
24442

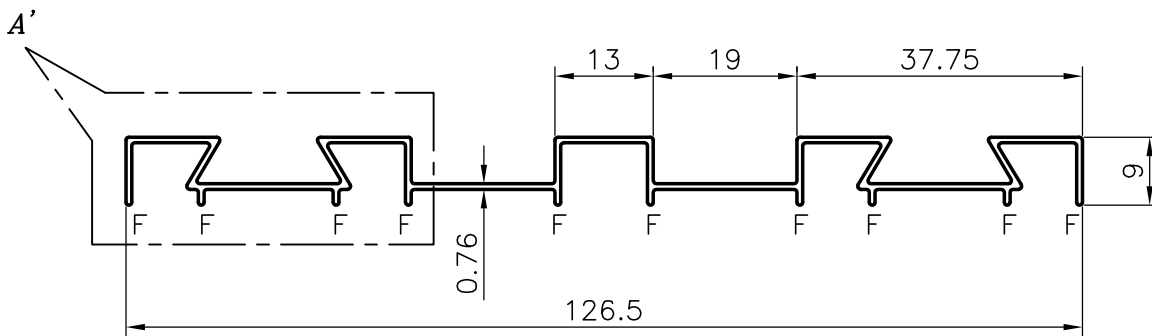

DETAIL A

F = FULL RADIUS
 GENERAL WALL THICKNESS = 0.76 mm



 SYMBOL OF QUALITY AN ISO 9001 COMPANY	JINDAL ALUMINIUM LTD. BANGALORE-560073 (INDIA)	NAME		DATE
		DRAWN	Malingappa	29.11.2003
1. ALL DIMENSIONS ARE IN mm. 2. ROUND OFF ALL SHARP CORNERS WITH 0.40 mm. 3. TOLERANCES WILL BE AS PER IS: 3965-1981 UNLESS OTHERWISE SPECIFIED		CHECKED		
		APPROVED		
PARTY'S NAME GENERAL CATEGORY, BANGALORE MARKET		SCALE		1:1
		AREA mm ²		172.5
PARTY'S DRAWING No. AS PER SAMPLE		PERIMETER mm.		438.5
		WEIGHT kg/m		0.466
ALLOY & TEMPER HE9 WP		DRAWING No.	SECTION No.	
		P-4600	-	
DESCRIPTION TRANSPORT SECTION		6552	6552	
		24442	24442	