

P-4623-2

6557

24447

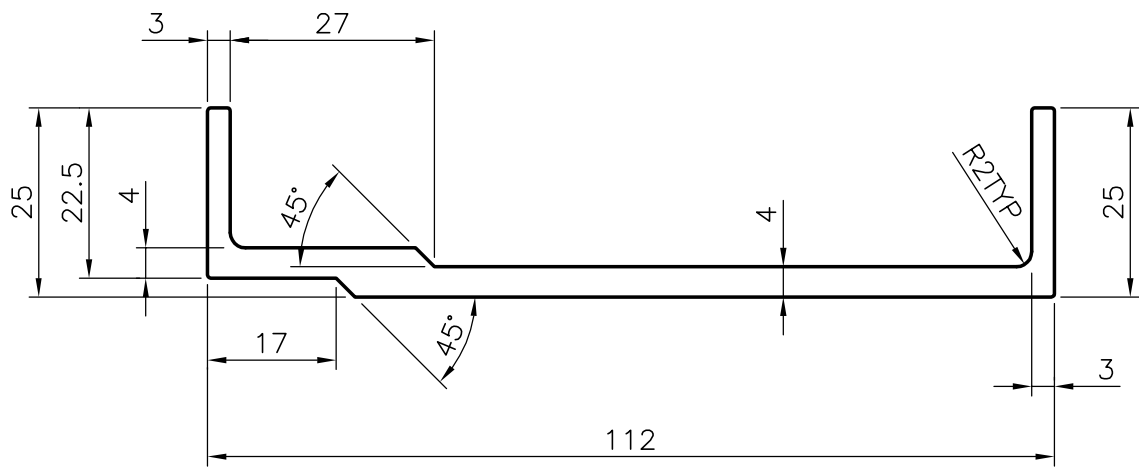

ALL OUTER SURFACES BETTER FINISH REQUIRED.



SYMBOL OF QUALITY
AN ISO 9001 COMPANY

JINDAL ALUMINIUM LTD.
BANGALORE-560073 (INDIA)

	NAME	DATE
DRAWN	RAGHAVENDRA	06-01-2004
CHECKED		
APPROVED		
SCALE		1:1
AREA mm ²		594.261
PERIMETER mm.		310.324
WEIGHT kg/m		1.605
DRAWING No.	SECTION No.	
P-4623-2	P-4623-2	
6557	6557	
24447	24447	

1. ALL DIMENSIONS ARE IN mm.
2. ROUND OFF ALL SHARP CORNERS WITH 0.40 mm.
3. TOLERANCES WILL BE AS PER IS: 3965-1981 UNLESS OTHERWISE SPECIFIED

PARTY'S NAME	GENERAL CATEGORY, COCHIN MARKET.
PARTY'S DRAWING No.	AS PER SAMPLE
ALLOY & TEMPER	HE9 WP
DESCRIPTION	TRANSPORT SECTION