

P-4572-1
7094
24448

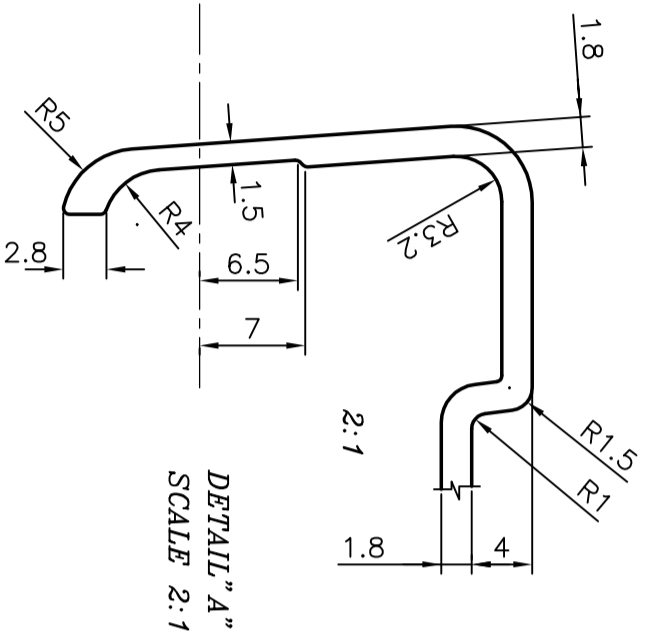
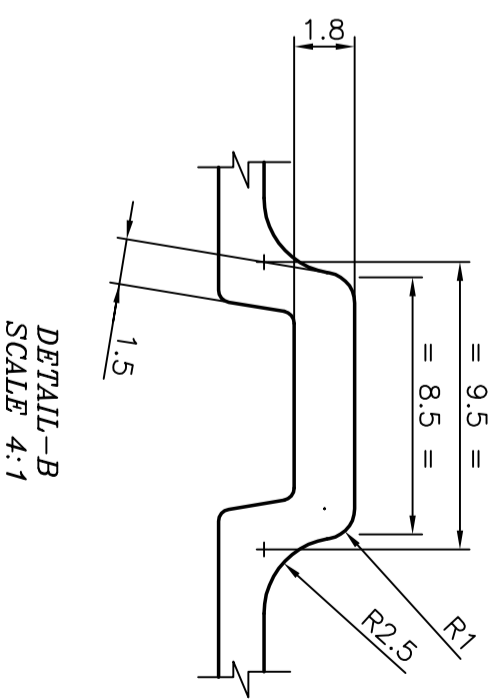
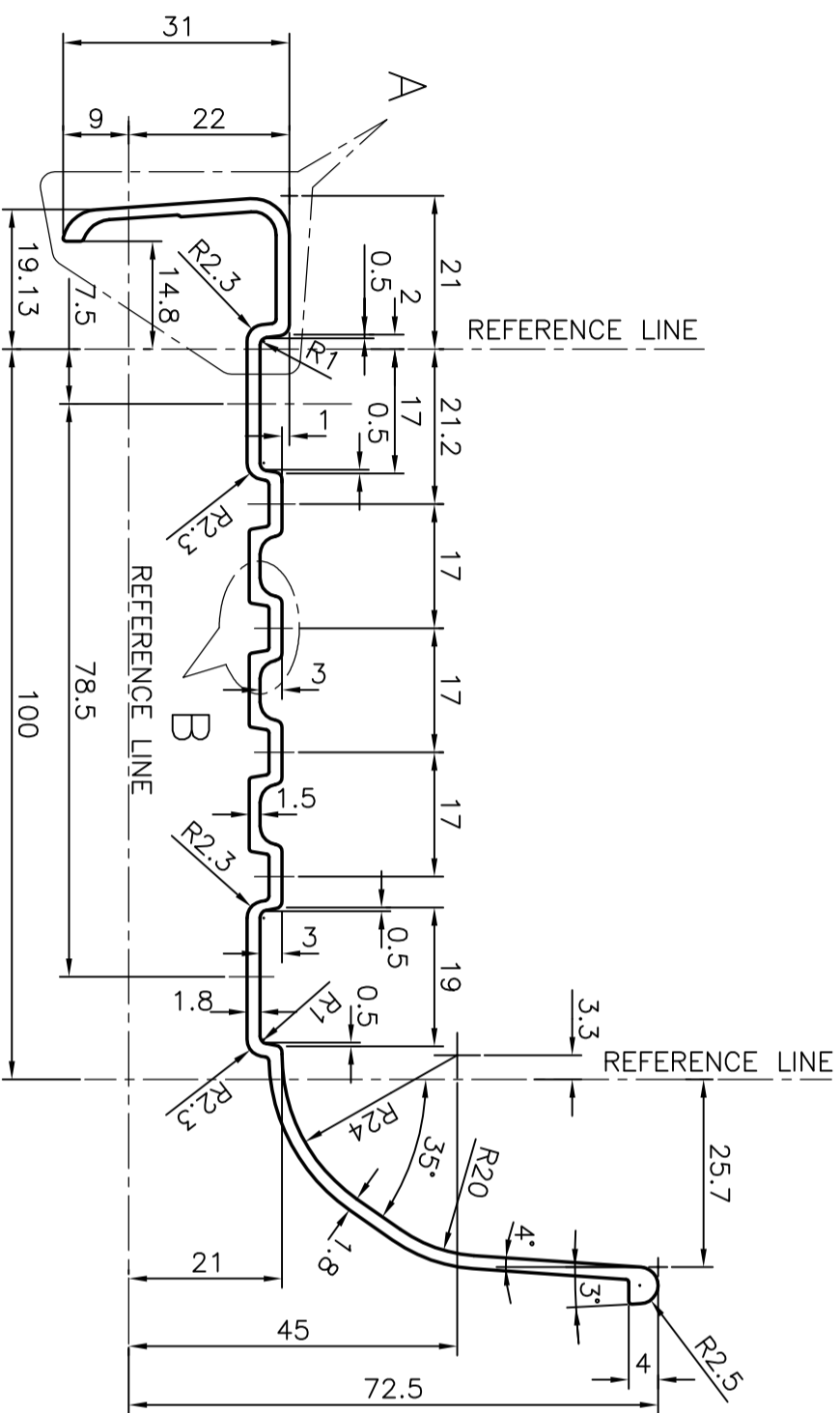

JINDAL
SYMBOL OF QUALITY
AN ISO 9001 COMPANY

JINDAL ALUMINIUM LTD.
BANGALORE-560073 (INDIA)

1. ALL DIMENSIONS ARE IN mm.
2. ROUND OFF ALL SHARP CORNERS WITH 0.40 mm.
3. TOLERANCES WILL BE AS PER IS: 3965-1981 UNLESS OTHERWISE SPECIFIED

PARTY'S NAME	GENERAL CATEGORY, DELHI MARKET	DRAWN	D K Show	DATE	26-11-03
PARTY'S DRAWING No.	LIGHTER SECTION OF 7901	CHECKED			
ALLOY & TEMPER	HE9 WP	APPROVED			
DESCRIPTION	TRANSPORT SECTION	SCALE	1:1		
		AREA mm ²	425.2		
		PERIMETER mm.	472.6		
		WEIGHT kg/m	1.148		
		DRAWING No.	P-4572-1	SECTION No.	
			7094		
			24448		