

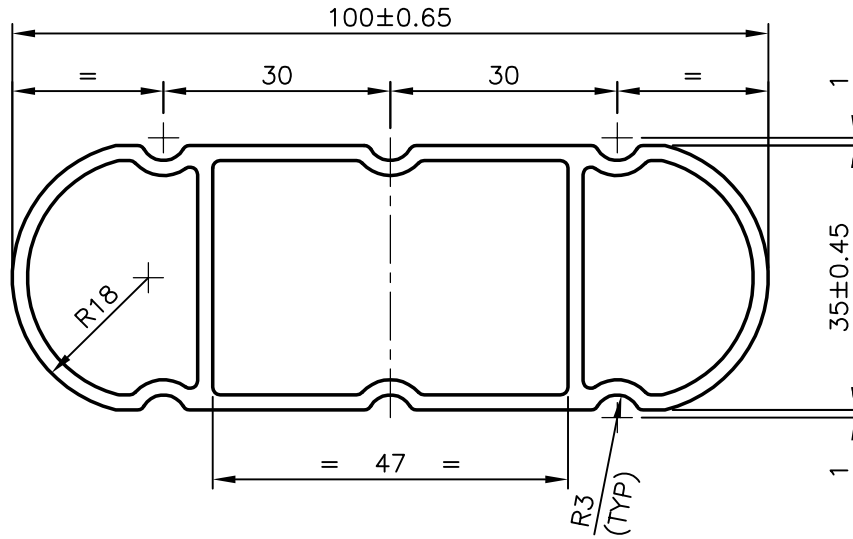

P-7482

24472



NOTE:-

1. UNSPECIFIED RADIUS = R1.00 mm
2. GENERAL WALL THICKNESS = 2±0.56

 SYMBOL OF QUALITY AN ISO 9001 COMPANY	<b>JINDAL ALUMINIUM LTD.</b> BANGALORE-560073 (INDIA)	NAME		DATE
		DRAWN	PRASANN.H	03-09-2007
1. ALL DIMENSIONS ARE IN mm. 2. ROUND OFF ALL SHARP CORNERS WITH 1.00 mm. 3. TOLERANCES WILL BE AS PER IS:6477-1983 UNLESS OTHERWISE SPECIFIED		CHECKED		
		APPROVED		
PARTY'S NAME SUN AUTO, COIMBATORE		SCALE		1:1
		AREA mm <sup>2</sup>		615.287
PARTY'S DRAWING No. AS PER DRAWING		PERIMETER mm.		249.771
		WEIGHT kg/m		1.661
ALLOY & TEMPER 6063 T5		DRAWING No.		SECTION No.
		P-7482		-
DESCRIPTION TRASPORT SECTION		24472		24472