

P-12047

24484

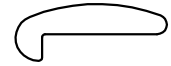

SCALE 1:1

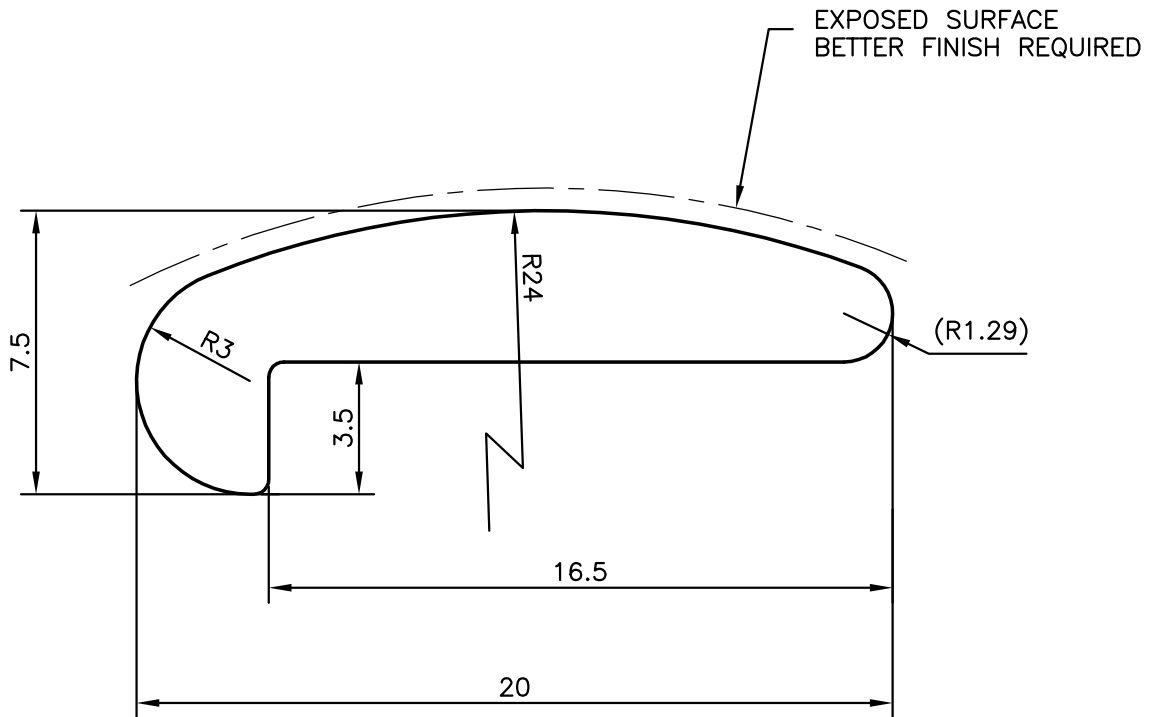

SYMBOL OF QUALITY
AN ISO 9001 COMPANY

JINDAL ALUMINIUM LTD.
BANGALORE-560073 (INDIA)

	NAME	DATE
DRAWN	RAGHAVENDRA	20-09-2012
CHECKED		
APPROVED	S.S.GARG	09-10-2012
SCALE		5:1
AREA mm ²		74.581
PERIMETER mm.		48.412
WEIGHT kg/m		0.201
DRAWING No.	SECTION No.	
P-12047	-	
24484	24484	

1. ALL DIMENSIONS ARE IN mm.
2. ROUND OFF ALL SHARP CORNERS WITH 0.40 mm.
3. TOLERANCES WILL BE AS PER BS:EN-755-9 UNLESS OTHERWISE SPECIFIED

PARTY'S NAME	TUBE AND FITTING STAHLHANDEL, GmbH, GERMANY
PARTY'S DRAWING No.	AS PER DRAWING (PROFILE-3)
ALLOY & TEMPER	6060 T66
DESCRIPTION/END USE	MISC. SECTION