

P-10802
S2869
24491

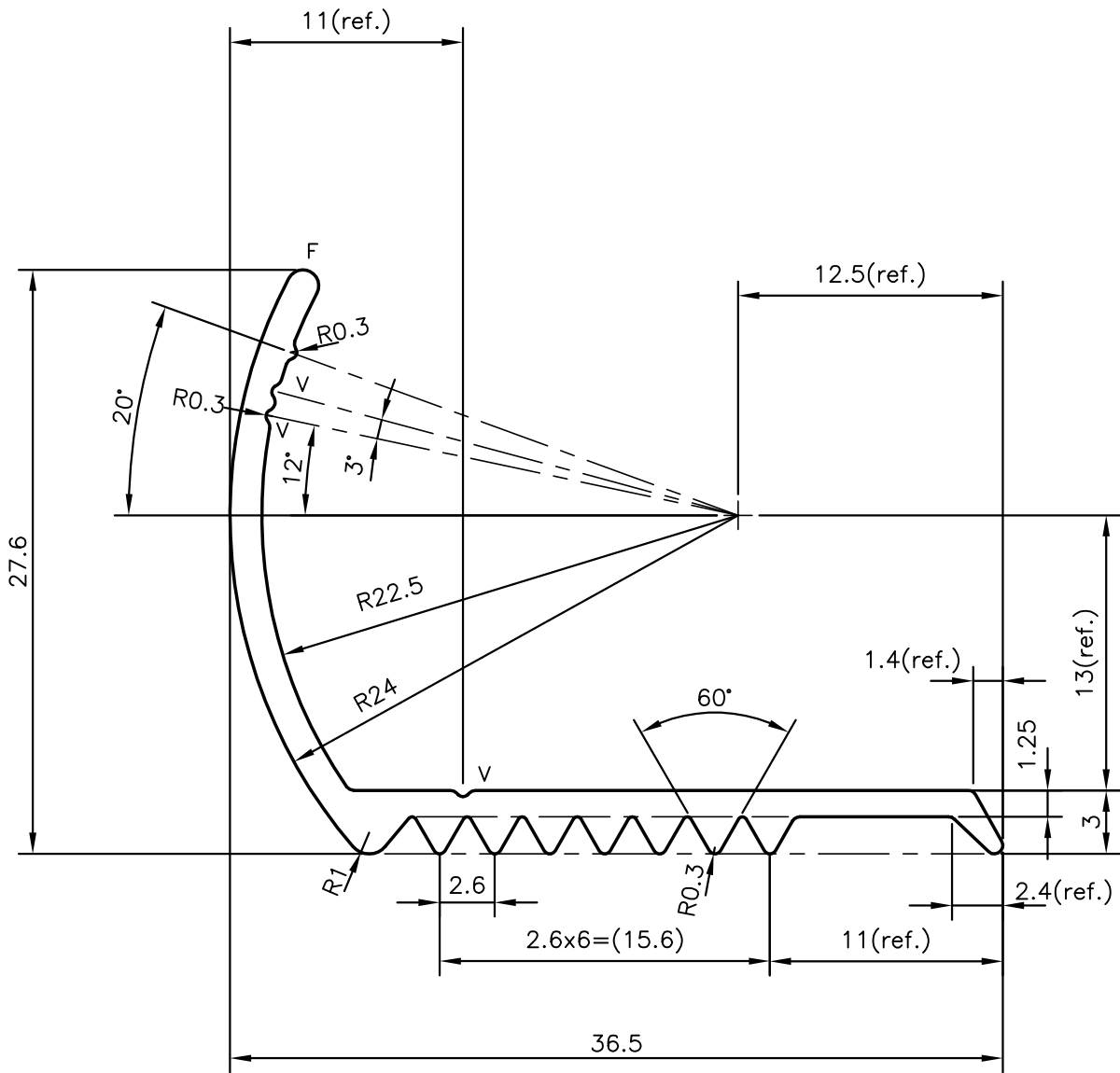

F= FULL RADIUS  
V= V GROOVE 0.3x90° ( 3 PLACES)

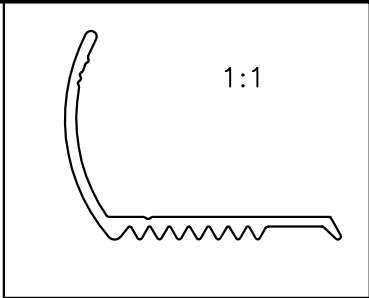

**JINDAL ALUMINIUM LTD.**  
**BANGALORE-560073 (INDIA)**

	NAME	DATE
DRAWN	J.P.KAUSHIK	01-03-2011
CHECKED		
APPROVED	S.S.GARG	11-03-2011

1. ALL DIMENSIONS ARE IN mm.
2. ROUND OFF ALL SHARP CORNERS WITH 0.40 mm.
3. TOLERANCES WILL BE AS PER IS:3965-1981 UNLESS OTHERWISE SPECIFIED

SCALE	3:1
AREA mm <sup>2</sup>	100.009
PERIMETER mm.	134.763
WEIGHT kg/m	0.270

PARTY'S NAME	MANJUL ENTERPRISES, MUMBAI
PARTY'S DRAWING No.	AS PER SAMPLE
ALLOY & TEMPER	HE9 WP
DESCRIPTION	MISC. SECTION

DRAWING No.	SECTION No.
P-10802	-
S2869	S2869
24491	24491