

P-11340-1

S3115

24496

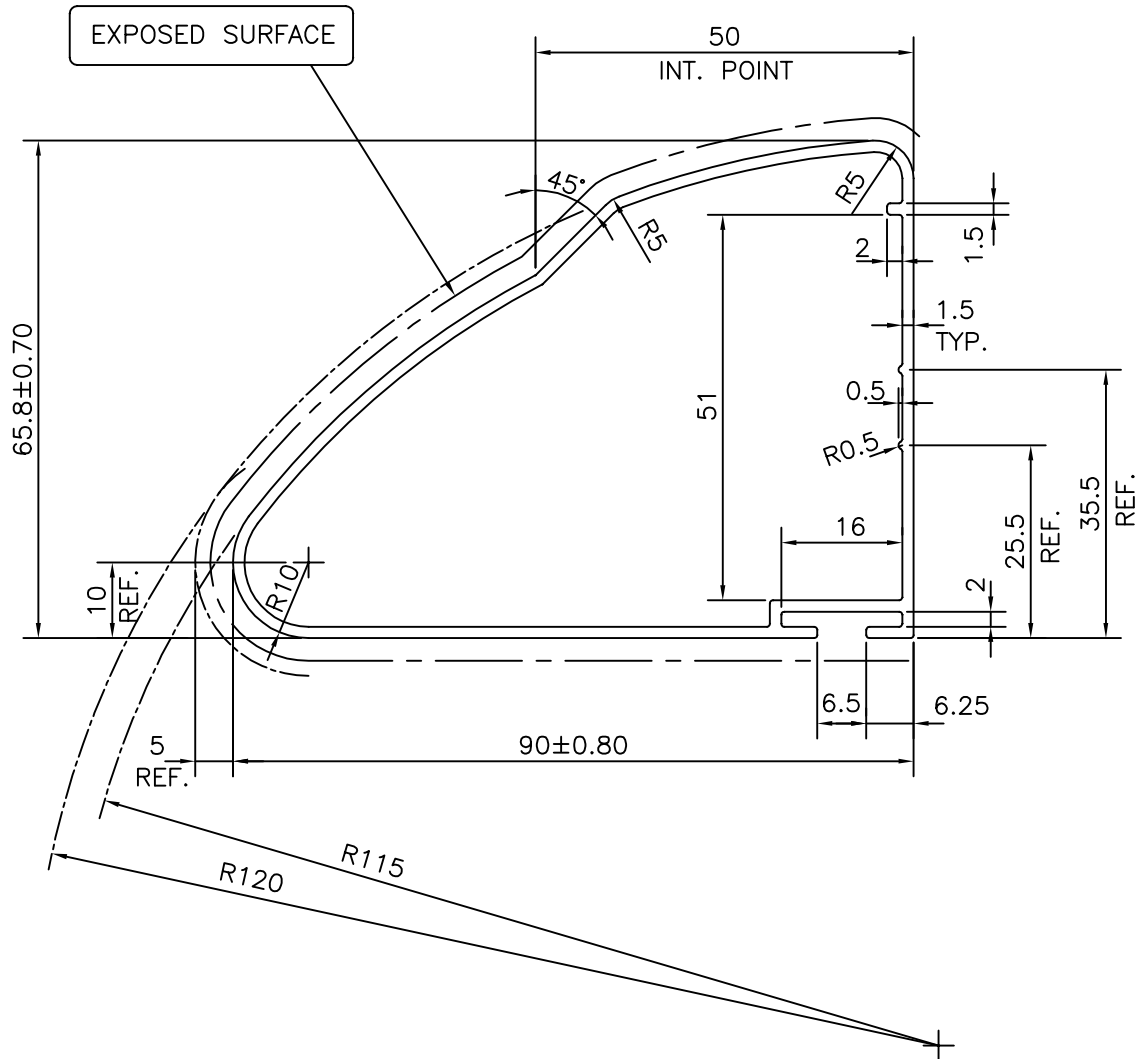

SYMBOL OF QUALITY
AN ISO 9001 COMPANY

JINDAL ALUMINIUM LTD.
BANGALORE-560073 (INDIA)

	NAME	DATE
DRAWN	PARVESH	29-11-2011
CHECKED		
APPROVED	S.S.GARG	01-12-2011

1. ALL DIMENSIONS ARE IN mm.
2. ROUND OFF ALL SHARP CORNERS WITH 0.40 mm.
3. TOLERANCES WILL BE AS PER, IS:6477-1983 UNLESS OTHERWISE SPECIFIED

SCALE	1:1
AREA mm ²	422.265
PERIMETER mm.	295.433
WEIGHT kg/m	1.140

PARTY'S NAME: TEAM CONCEPTS PVT. LTD., BANGALORE

PARTY'S DRAWING No.: YRC-001-WC

ALLOY & TEMPER: 6063 T5

DESCRIPTION: FRONT & REAR MISC. TUBE

DRAWING No.	SECTION No.
P-11340-1	-
S3115	S3115
24496	24496