

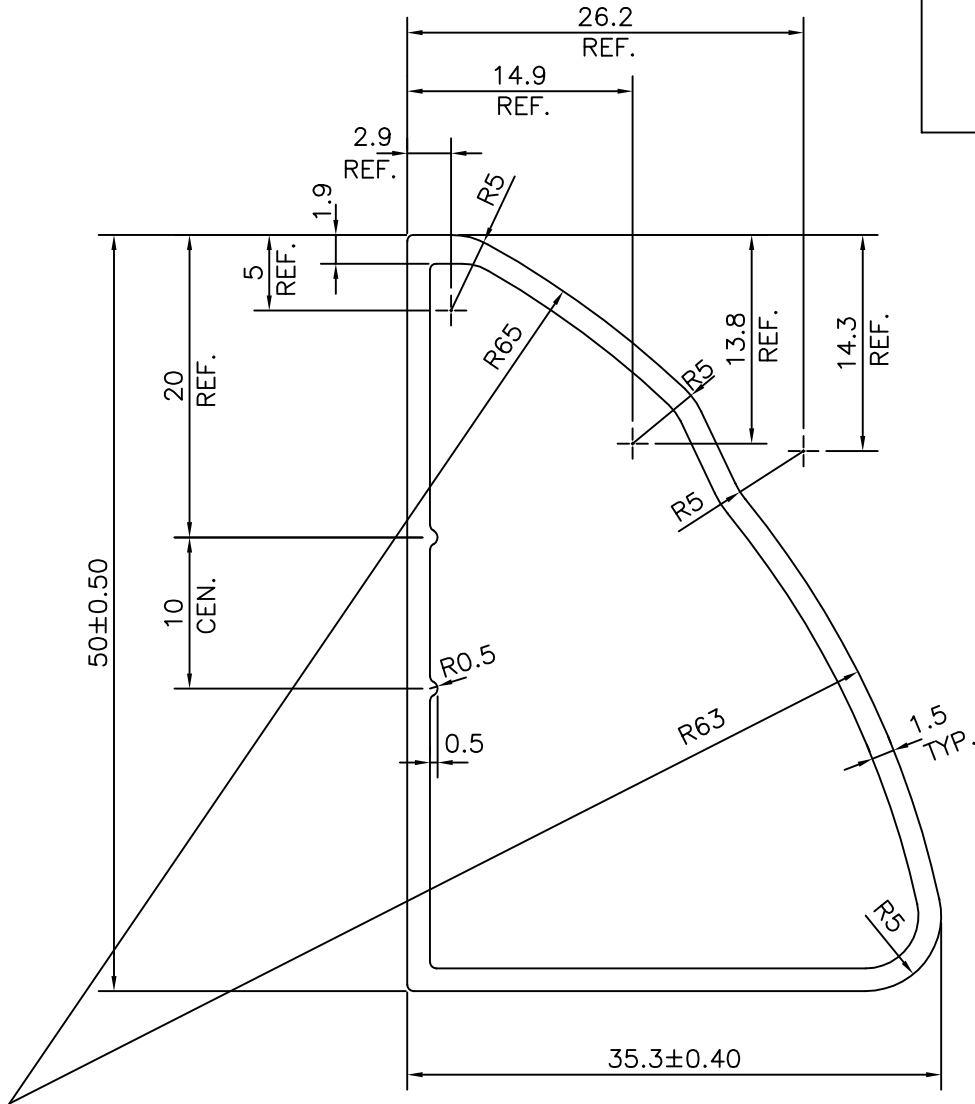

|         |
|---------|
| P-11341 |
| S3116   |
| 24497   |

EXPOSED SURFACE

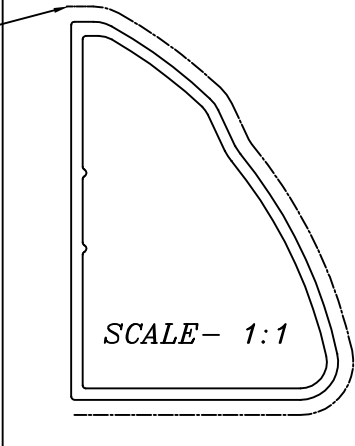

SCALE- 1:1

|   |  |                      |          |             |
|---|--|----------------------|----------|-------------|
| <br>SYMBOL OF QUALITY<br>AN ISO 9001 COMPANY                       | <b>JINDAL ALUMINIUM LTD.</b><br>BANGALORE-560073 (INDIA) | DRAWN                | NAME     | DATE        |
|   |  | CHECKED              | PARVESH  | 24-11-2011  |
| 1. ALL DIMENSIONS ARE IN mm.<br>2. ROUND OFF ALL SHARP CORNERS WITH 0.40 mm.<br>3. TOLERANCES WILL BE AS PER, IS:6477-1983 UNLESS OTHERWISE SPECIFIED | PARTY'S NAME<br>TEAM CONCEPTS PVT. LTD., BANGALORE       | APPROVED             | S.S.GARG | 01-12-2011  |
|   |  | SCALE                |          | 2:1         |
|   |  | AREA mm <sup>2</sup> |          | 217.223     |
| PARTY'S DRAWING No.<br>YRC-002  | ALLOY & TEMPER<br>6063 T5                                | PERIMETER mm.        |          | 148.551     |
|   |  | WEIGHT kg/m          |          | 0.587       |
| DESCRIPTION<br>MISC. TUBE   |  | DRAWING No.          |          | SECTION No. |
|   |  | P-11341              |          | -           |
|   |  | S3116                |          | S3116       |
|   |  | 24497                |          | 24497       |