

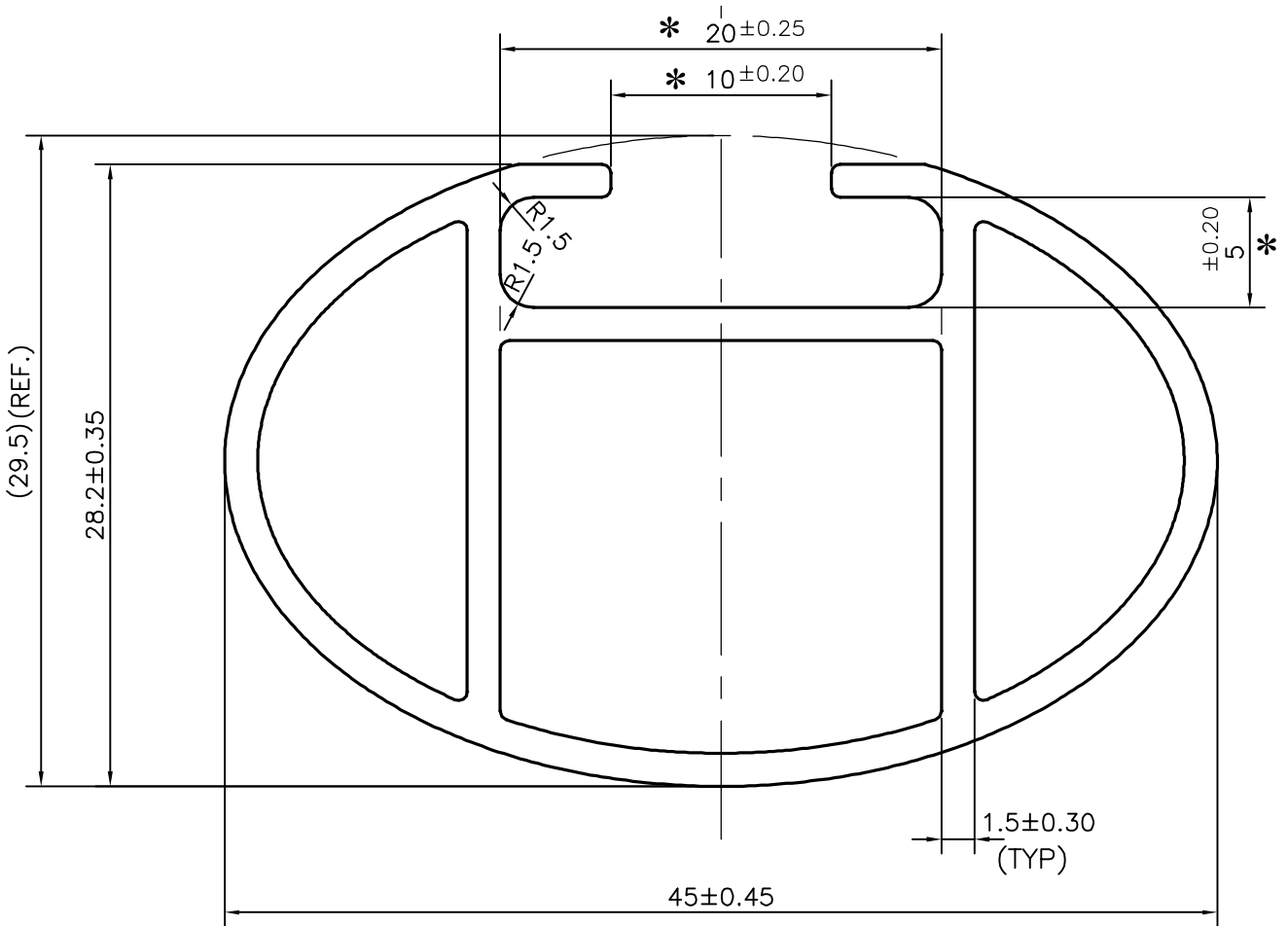

P-13401-1
S4020
24501

EXPOSED SURFACE

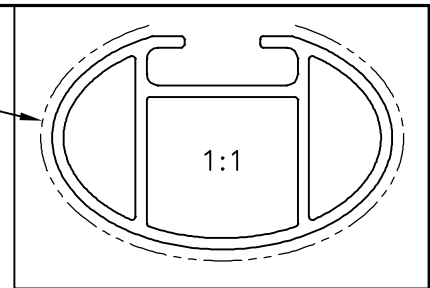

* - CRITICAL DIMENSIONS.

 SYMBOL OF QUALITY AN ISO 9001 COMPANY	JINDAL ALUMINIUM LTD. BANGALORE-560073 (INDIA)	NAME	DATE
		DRAWN	SRIYATHSA 06-02-2014
		CHECKED	
		APPROVED	S.S.GARG 10-02-2014
1. ALL DIMENSIONS ARE IN mm. 2. ROUND OFF ALL SHARP CORNERS WITH 0.40 mm. 3. TOLERANCES WILL BE AS PER IS:6477-1983 , UNLESS OTHERWISE SPECIFIED		SCALE	3:1
		AREA mm ²	255.069
		PERIMETER mm.	147.786
		WEIGHT kg/m	0.689
PARTY'S NAME	TEAM CONCEPT PVT. LTD., BANGALORE	DRAWING No.	SECTION No.
PARTY'S DRAWING No.	Rc660-001	P-13401-1	-
ALLOY & TEMPER	6063 T5	S4020	S4020
		24501	24501
DESCRIPTION	MISC. TUBE		