

P-15391

24503

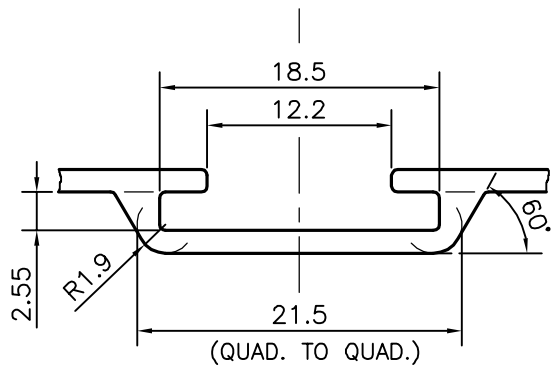

**DETAILS OF "A"**  
**SCALE 2:1**

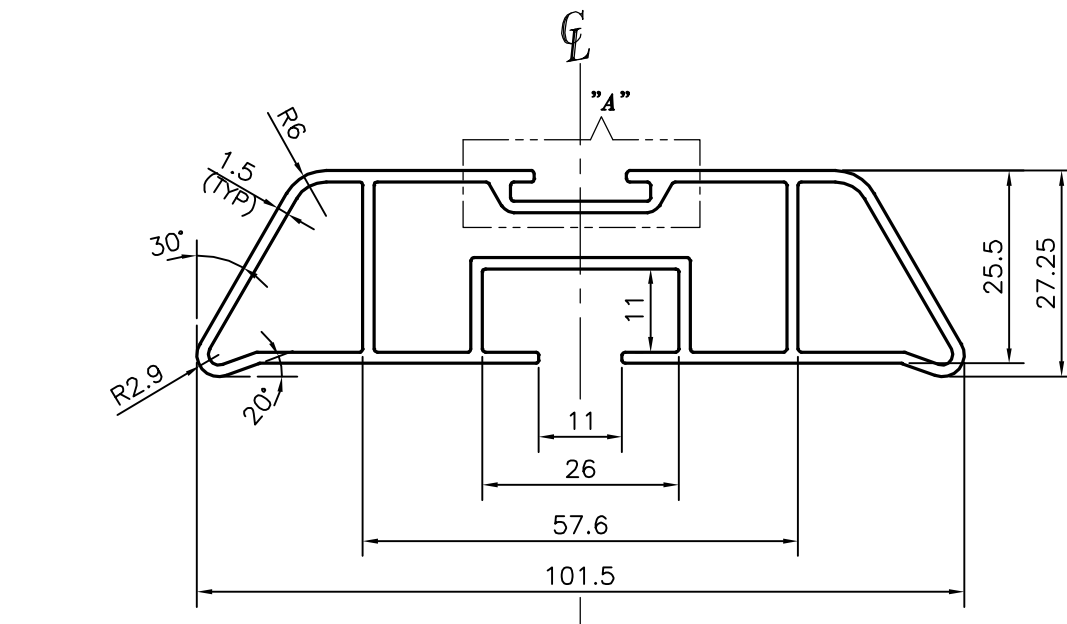

SYMBOL OF QUALITY  
AN ISO 9001 COMPANY

**JINDAL ALUMINIUM LTD.**  
**BANGALORE-560073 (INDIA)**

	NAME	DATE
DRAWN	J.P.KAUSHIK	03-12-2015
CHECKED		
APPROVED	S.S.GARG	08-01-2016
SCALE		1:1
AREA mm <sup>2</sup>		496.388
PERIMETER mm.		307.27
WEIGHT kg/m		1.340
DRAWING No.		SECTION No.
P-15391		-
24503		24503

1. ALL DIMENSIONS ARE IN mm.
2. ROUND OFF ALL SHARP CORNERS WITH 0.40 mm.
3. TOLERANCES WILL BE AS PER IS:6477-1983 ,UNLESS OTHERWISE SPECIFIED

PARTY'S NAME	GENERAL CATEGORY, BANGALORE MARKET
PARTY'S DRAWING No.	MODIFIED OF SECTION No:-24490
ALLOY & TEMPER	HE9 WP
DESCRIPTION	MISC. PROFILE