

P-13264-1

S3950

24504

EXPOSED
SURFACE

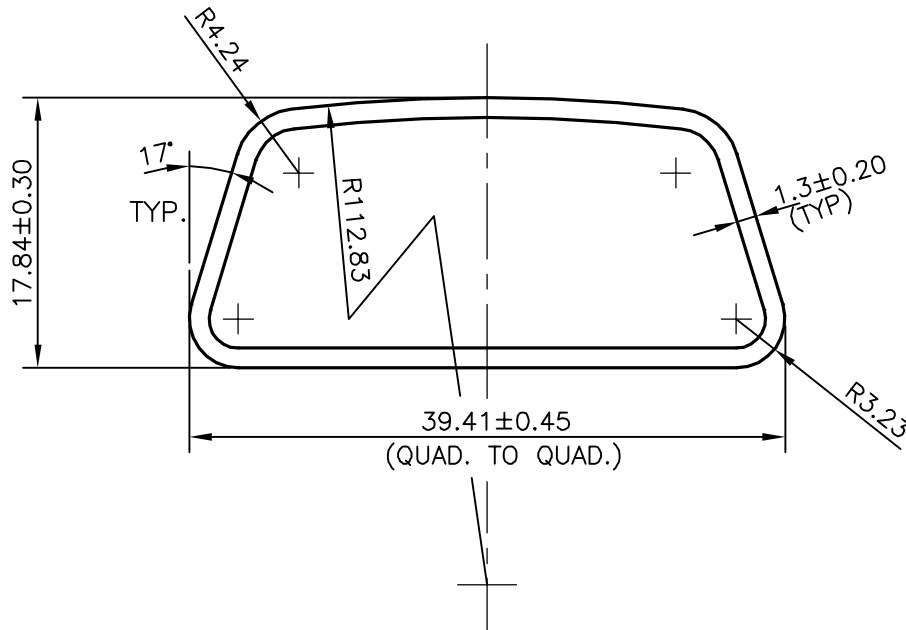
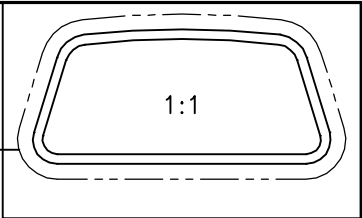

SYMBOL OF QUALITY
AN ISO 9001 COMPANY

JINDAL ALUMINIUM LTD.
BANGALORE-560073 (INDIA)

	NAME	DATE
DRAWN	SRIVATHSA	14-12-2013
CHECKED		
APPROVED	S.S.GARG	17-12-2013
SCALE		2:1
AREA mm ²		126.787
PERIMETER mm.		101.613
WEIGHT kg/m		0.342
DRAWING No.	SECTION No.	
P-13264-1	-	
S3950	S3950	
24504	24504	

1. ALL DIMENSIONS ARE IN mm.
2. ROUND OFF ALL SHARP CORNERS WITH 0.40 mm.
3. TOLERANCES WILL BE AS PER IS:6477-1983 , UNLESS OTHERWISE SPECIFIED

PARTY'S NAME	TEAM CONCEPTS PVT. LTD., BANGALORE
PARTY'S DRAWING No.	AS PER AUTOCAD DRAWING & REQUIREMENT
ALLOY & TEMPER	6063 T5
DESCRIPTION	RAIL SECTION