

P-15444
S4805
24514

EXPOSED SURFACE

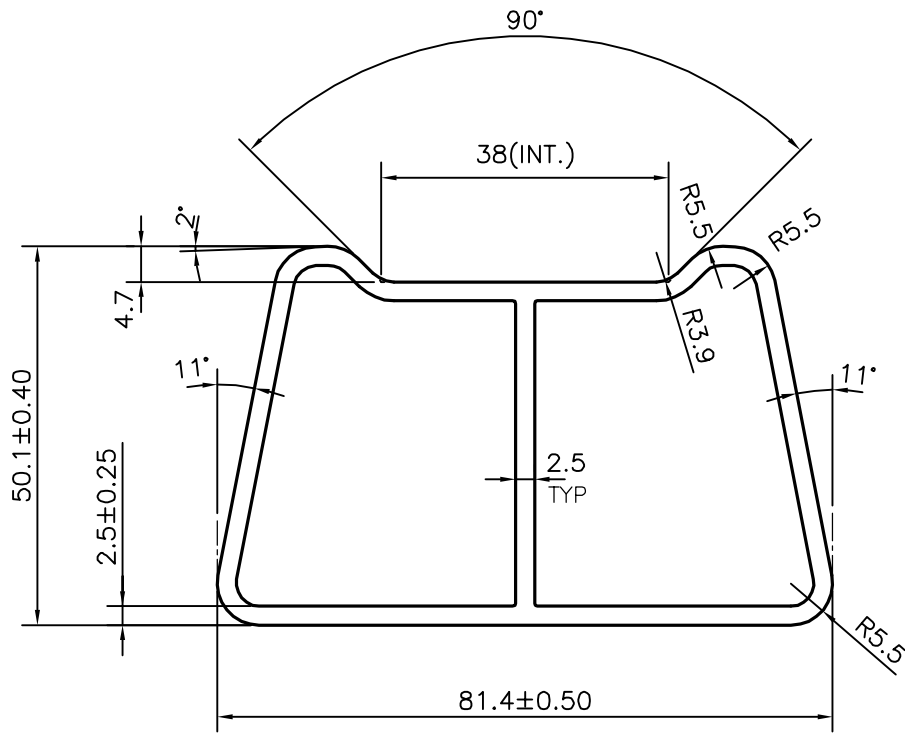
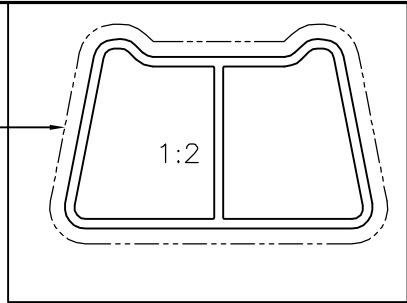

JINDAL ALUMINIUM LTD.
BANGALORE-560073 (INDIA)

	NAME	DATE
DRAWN	J.P.KAUSHIK	17-12-2015
CHECKED		
APPROVED	S.S.GARG	22-12-2015
SCALE		1:1
AREA mm ²		688.536
PERIMETER mm.		242.813
WEIGHT kg/m		1.859
DRAWING No.	SECTION No.	
P-15444	-	
S4805	S4805	
24514	24514	

1. ALL DIMENSIONS ARE IN mm.
2. ROUND OFF ALL SHARP CORNERS WITH 0.40 mm.
3. TOLERANCES WILL BE AS PER IS:6477-1983 , UNLESS OTHERWISE SPECIFIED

PARTY'S NAME	TEAM CONCEPTS PVT. LTD., BANGALORE
PARTY'S DRAWING No.	AS PER AutoCAD DRAWING-2SJ BAR 000
ALLOY & TEMPER	6063 T6
DESCRIPTION	2SJ RR BAR SECTION