

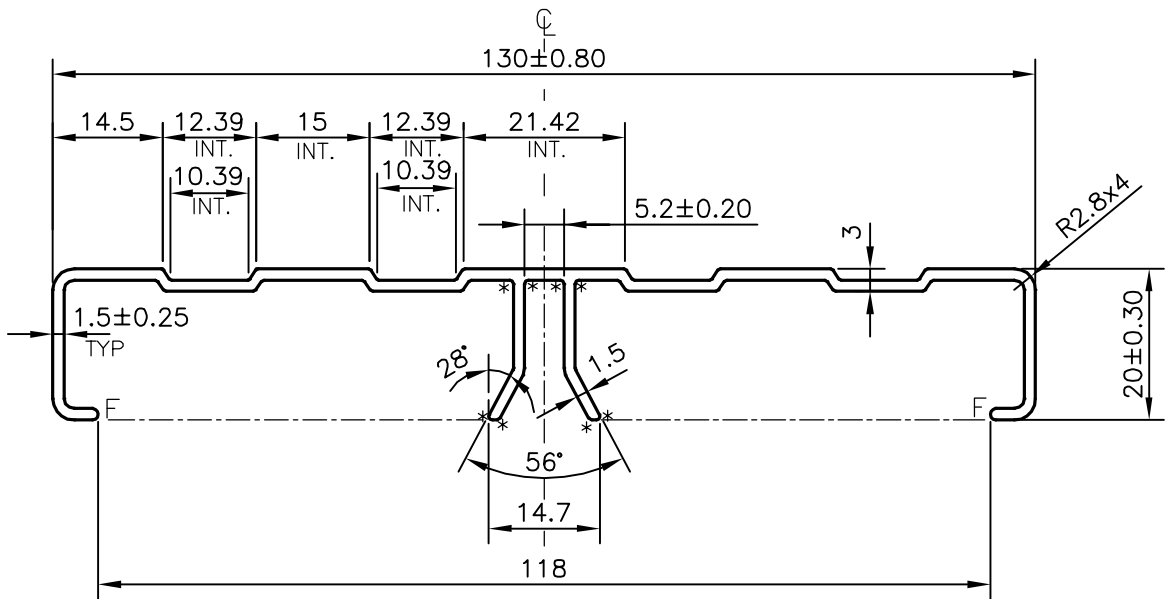

P-15601-1
S4847
24516

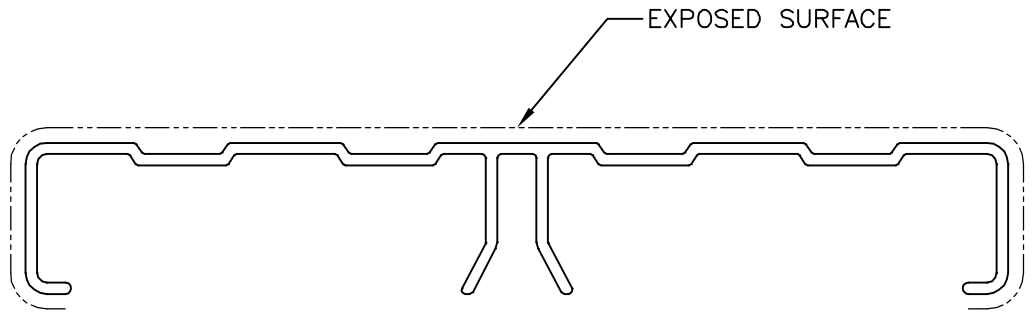

* = 0.5 RADIUS (8 PLACE)
F = FULL RADIUS (2 PLACE)

 SYMBOL OF QUALITY AN ISO 9001 COMPANY	JINDAL ALUMINIUM LTD. BANGALORE-560073 (INDIA)	NAME		DATE	
		DRAWN	J.P.KAUSHIK	16-02-2016	
1. ALL DIMENSIONS ARE IN mm. 2. ROUND OFF ALL SHARP CORNERS WITH 0.40 mm. 3. TOLERANCES WILL BE AS PER BS:EN-755-9 , UNLESS OTHERWISE SPECIFIED		CHECKED			
		APPROVED		B. NATARAJ 19-02-2016	
PARTY'S NAME		TEAM CONCEPTS PVT. LTD., BANGALORE		SCALE	1:1
		PARTY'S DRAWING No.		MODIFIED OF SECTION No:-X1935	AREA mm ²
ALLOY & TEMPER		6063 T5		PERIMETER mm.	433.975
		DESCRIPTION		LOAD ALUMINUM BIG SECTION	WEIGHT kg/m
		DRAWING No.		SECTION No.	
		P-15601-1		-	
		S4847		S4847	
		24516		24516	