

IAL-D-4809

24526

DETAIL-A
SCALE 2:1DETAIL-B
SCALE 2:1**NOTE:-****F= FULL RADIUS (6 PLACES)**

1. STRAIGHTNESS= 1.7mm/M
2. TWIST= 1.7mm/M
3. ANGULARITY= $\pm 2^\circ$
4. FLATNESS= 0.007xWIDTH

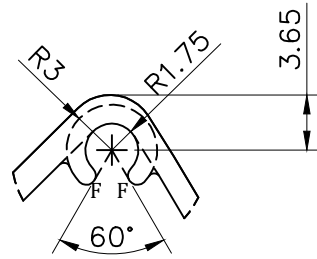
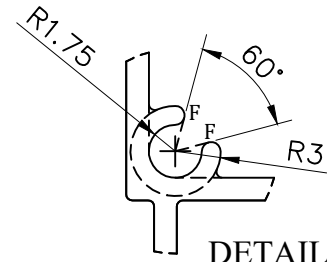
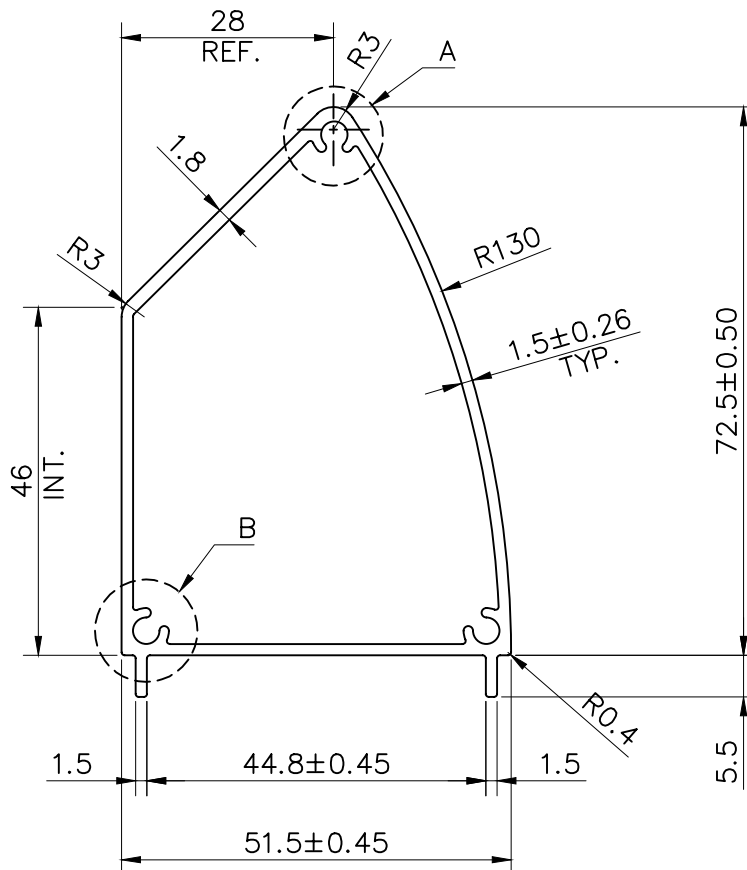

SYMBOL OF QUALITY
AN ISO 9001 COMPANY

JINDAL ALUMINIUM LTD.
BHIWADI-301019 (INDIA)

	NAME	DATE
DRAWN	ASHUTOSH	15-06-2023
CHECKED		
APPROVED		
SCALE		1:1
AREA mm ²		361.45
PERIMETER mm.		234.62
WEIGHT kg/m		0.976
DRAWING No.	SECTION No.	
IAL-D-4809		
24526	24526	

1. ALL DIMENSIONS ARE IN mm.
2. ROUND OFF ALL SHARP CORNERS WITH 0.40 mm.
3. TOLERANCES WILL BE AS PER BS:EN-755-9 , UNLESS OTHERWISE SPECIFIED

PARTY'S NAME	RAVISTAR
PARTY'S DRAWING No.	AS PER DRAWING
ALLOY & TEMPER	6063-T6
DESCRIPTION	INDUSTRIAL MISC. SECTION