

P-18103

S5795

24581

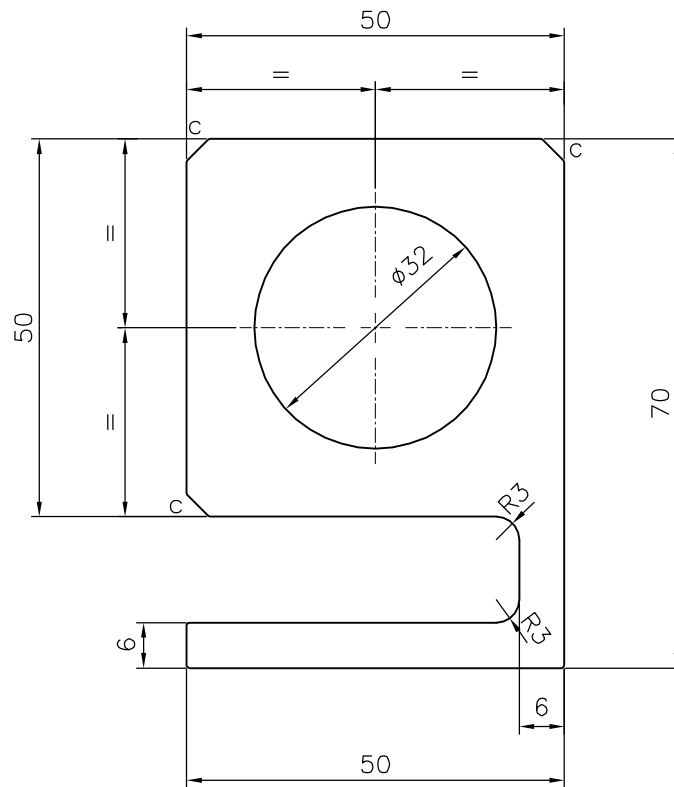

C =CHAMFER 3x45° (3 PLACES)



SYMBOL OF QUALITY
AN ISO 9001 COMPANY

JINDAL ALUMINIUM LTD.
BANGALORE-560073 (INDIA)

	NAME	DATE
DRAWN	J.P.KAUSHIK	13-04-2018
CHECKED		
APPROVED	B.NATARAJA	24-04-2018
SCALE		1:1
AREA mm ²		2069.991
PERIMETER mm.		319.534
WEIGHT kg/m		5.589
DRAWING No.	SECTION No.	
P-18103	-	
S5795	S5795	
24581	24581	

1. ALL DIMENSIONS ARE IN mm.
2. ROUND OFF ALL SHARP CORNERS WITH 0.40 mm.
3. TOLERANCES WILL BE AS PER IS:6477-1983 , UNLESS OTHERWISE SPECIFIED

PARTY'S NAME	HANSPAL TRADERS, KAPURTHALA
PARTY'S DRAWING No.	AS PER DRAWING
ALLOY & TEMPER	6063 T6
DESCRIPTION	GUIDE BLOCK IH