

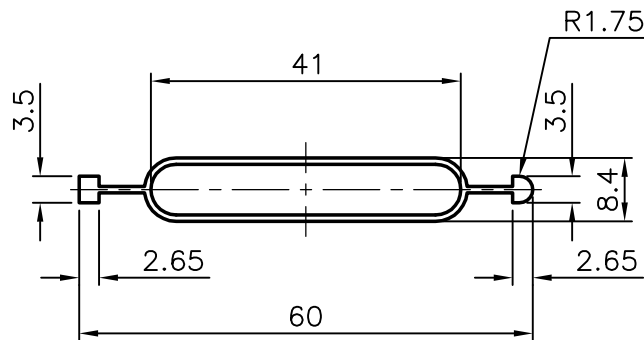

7242

24732



1. NO. OF PIECES REQD. IN 100 KGS. :- 95 (AVERAGE)
2. GENERAL WALL THICKNESS :-0.85 MM.

 SYMBOL OF QUALITY AN ISO 9002 COMPANY	<b>JINDAL ALUMINIUM LTD.</b> <b>BANGALORE-560073 (INDIA)</b>				NAME	DATE
				DRAWN	R.D.SHARMA	20.12.90
1. ALL DIMENSIONS ARE IN MM. 2. ROUND OFF SHARP CORNERS WITH 0.4mm R. 3. TOLERANCES WILL BE AS PER IS:6477-1983,UNLESS OTHERWISE SPECIFIED.				CHECKED		
				APPROVED		
				SCALE	1:1	
PARTY'S NAME	-			WEIGHT kg/m	0.287	
PARTY'S DRAWING No.	-	FINISH	-	SECTION No.	<del>XXXXXX</del> 24732	
ALLOY & TEMPER	HE 9 WP	LENGTH:	3658 MM	DRAWING No.	<del>XXXXXX</del> 24732	
DESCRIPTION	TEXTILE SECTION					