

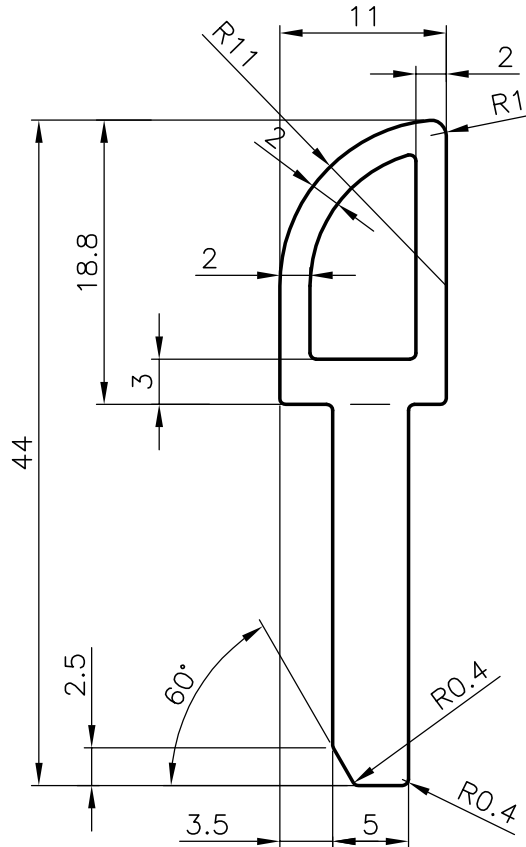

P-2615
S521
7274
24759

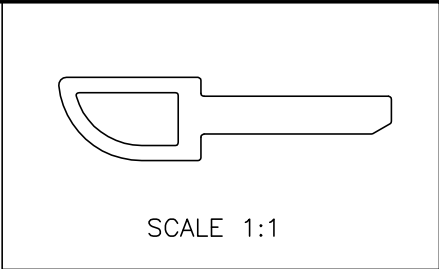

TOLERANCE ON TWIST AND STRAIGHTNESS = 1.70mm/M

ISSUE-2 RADIUS CHANGED FROM 2.24 TO 0.40mm

 SYMBOL OF QUALITY AN ISO 9001 COMPANY	<b>JINDAL ALUMINIUM LTD.</b> BANGALORE-560073 (INDIA)	NAME		DATE
		DRAWN	RAGHAVENDRA	02-11-2004
1. ALL DIMENSIONS ARE IN mm. 2. ROUND OFF ALL SHARP CORNERS WITH 0.40 mm. 3. TOLERANCES WILL BE AS PER IS:3965-1981 UNLESS OTHERWISE SPECIFIED		CHECKED		
		APPROVED		
PARTY'S NAME LAKSHMI MACHINE WORKS LTD, COIMBATORE		SCALE		2:1
		AREA mm <sup>2</sup>		225.631
PARTY'S DRAWING No. AS PER SKETCH		PERIMETER mm.		102.914
		WEIGHT kg/m		0.609
ALLOY & TEMPER HE9 M		DRAWING No.		P-2615
		SECTION No.		-
DESCRIPTION TOP COMB BLADE HOLDER		S521		S521
		7274		7274-ISSUE-2
		24759		24759