

INCASE IF O.D. IS 30.6 mm. , THE GROOVE I.D. SHOULD BE 27.9 mm. . IF THE O.D. IS 30 mm. THE GROOVE I.D. SHOULD BE 27.30 mm.

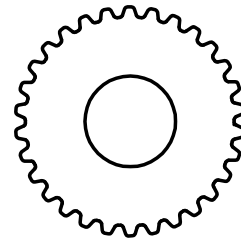

SCALE 1:1

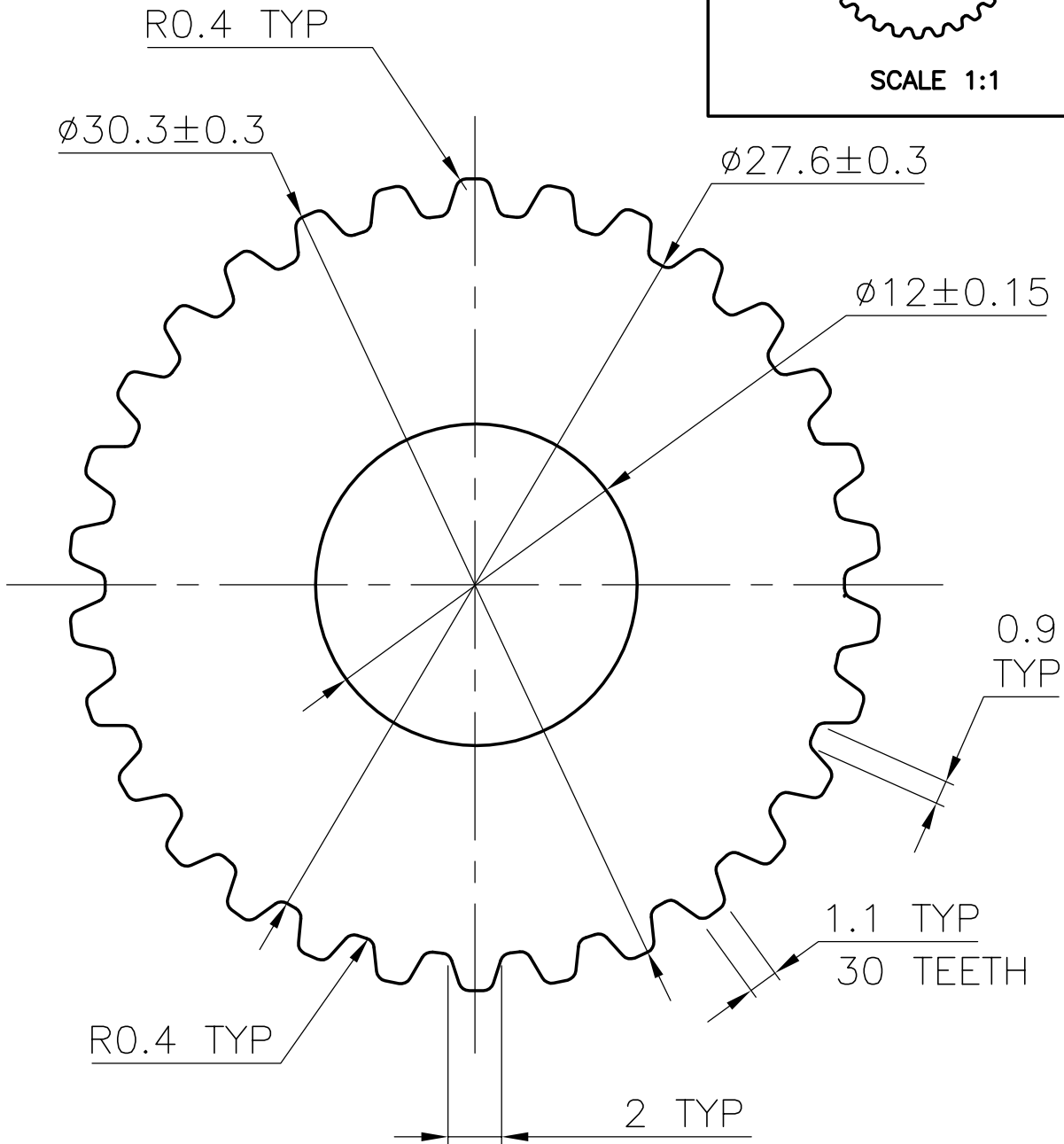

24762  
7277  
S584



SYMBOL OF QUALITY  
AN ISO 9002 COMPANY

**JINDAL ALUMINIUM LTD.**  
BANGALORE-560073 (INDIA)

	NAME	DATE
DRAWN	RANGASWAMY	30-10-2K
CHECKED		
APPROVED		

1. ALL DIMENSIONS ARE IN mm.
2. ROUND OFF ALL SHARP CORNERS WITH 0.40 mm.
3. TOLERANCES WILL BE AS PER I.S. 6477-1983 UNLESS OTHERWISE SPECIFIED

SCALE	4:1
WEIGHT kg/m	1.479
SECTION No.	24762

PARTY'S NAME	TEX-TECH INDUSTRIES, COIMBATORE
PARTY'S DRAWING No.	AS PER DRAWING
ALLOY & TEMPER	HE9 WP
DESCRIPTION	FEED ROLLER

DRAWING No.  
24762