

P-5553

S1511

24786

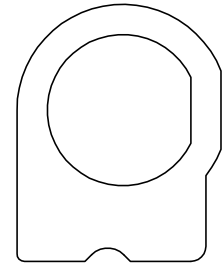

SCALE 1:1

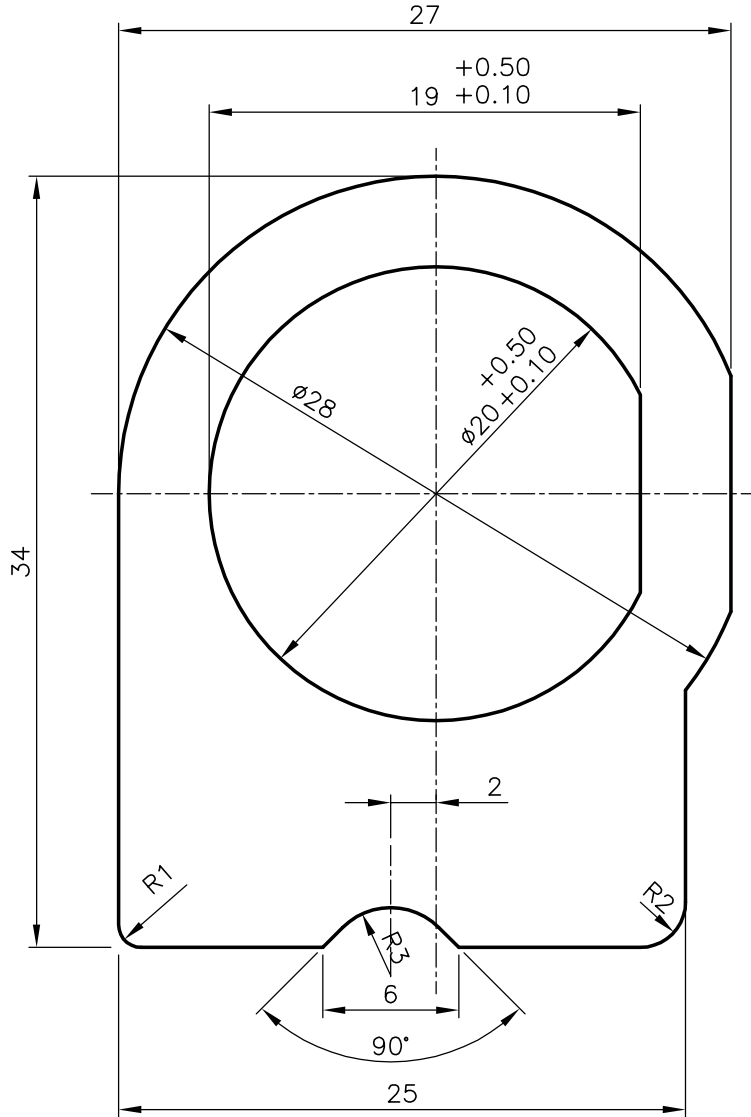

SYMBOL OF QUALITY
AN ISO 9001 COMPANY

JINDAL ALUMINIUM LTD.
BANGALORE-560073 (INDIA)

	NAME	DATE
DRAWN	RAGHAVENDRA	02-06-2005
CHECKED		
APPROVED		
SCALE		3:1
AREA mm ²		502.413
PERIMETER mm.		109.744
WEIGHT kg/m		1.357
DRAWING No.	SECTION No.	
P-5553	-	
S1511	S1511	
24786	24786	

1. ALL DIMENSIONS ARE IN mm.
2. ROUND OFF ALL SHARP CORNERS WITH 0.40 mm.
3. TOLERANCES WILL BE AS PER IS:6477-1983 UNLESS OTHERWISE SPECIFIED

PARTY'S NAME	KIRLOSKAR TOYODA TEXTILE MACHINERY PVT. LTD, BANGALORE
PARTY'S DRAWING No.	R2531-11060
ALLOY & TEMPER	6063 T5
DESCRIPTION	TEXTILE MACHINERY SECTION