

P-7868-5

24796

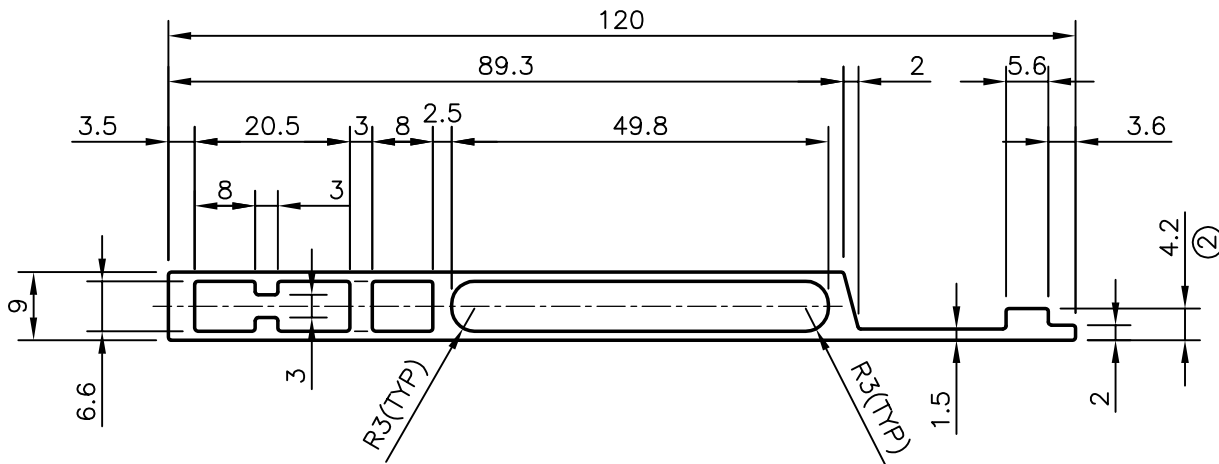

TO CHECK WITH MATCHING PLASTIC PART

ISSUE - 2

DIMENSION CHANGED FROM 4.50 mm TO 4.20 mm
 AND ALSO CHANGED FROM 1.020 kg/m TO 1.015 kg/m



SYMBOL OF QUALITY
 AN ISO 9001 COMPANY

JINDAL ALUMINIUM LTD.
 BANGALORE-560073 (INDIA)

	NAME	DATE
DRAWN	PRASANNA.H	14-06-2008
CHECKED		
APPROVED		

1. ALL DIMENSIONS ARE IN mm.
2. ROUND OFF ALL SHARP CORNERS WITH 0.40 mm.
3. TOLERANCES WILL BE AS PER IS:6477-1983 UNLESS OTHERWISE SPECIFIED

SCALE	1:1
AREA mm ²	376.053
PERIMETER mm.	260.108
WEIGHT kg/m	1.015 (2)

PARTY'S NAME	GENERAL CATEGORY, MUMBAI MARKET
PARTY'S DRAWING No.	AS PER SKETCH
ALLOY & TEMPER	HE9 WP
DESCRIPTION	TEXTILE SECTION

DRAWING No.	SECTION No.
P-7868-5	-
24796	24796-ISSUE-2