

P-9736

S2433

24823

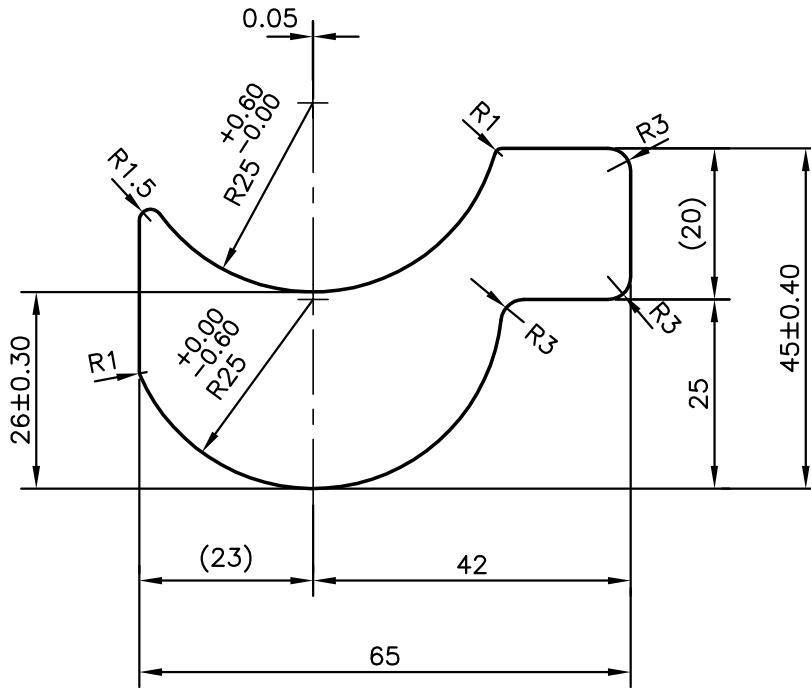

BEND/ TWIST :- 1.7mm/M



SYMBOL OF QUALITY
AN ISO 9001 COMPANY

JINDAL ALUMINIUM LTD.
BANGALORE-560073 (INDIA)

	NAME	DATE
DRAWN	J.P.KAUSHIK	11-01-2010
CHECKED		
APPROVED		

1. ALL DIMENSIONS ARE IN mm.
2. ROUND OFF ALL SHARP CORNERS WITH 0.40 mm.
3. TOLERANCES WILL BE AS PER IS:3965-1981, UNLESS OTHERWISE SPECIFIED

SCALE	1:1
AREA mm ²	1579.445
PERIMETER mm.	200.11
WEIGHT kg/m	4.265

PARTY'S NAME KIRLOSKAR TOYODA TEXTILE MACHINERY PVT. LTD., BANGALORE

DRAWING No. SECTION No.

PARTY'S DRAWING No. SK2110

P-9736

-

ALLOY & TEMPER 6061 T5

S2433

S2433

24823

24823

DESCRIPTION

TEXTILE SECTION