

P-11058-1

S2996

24832

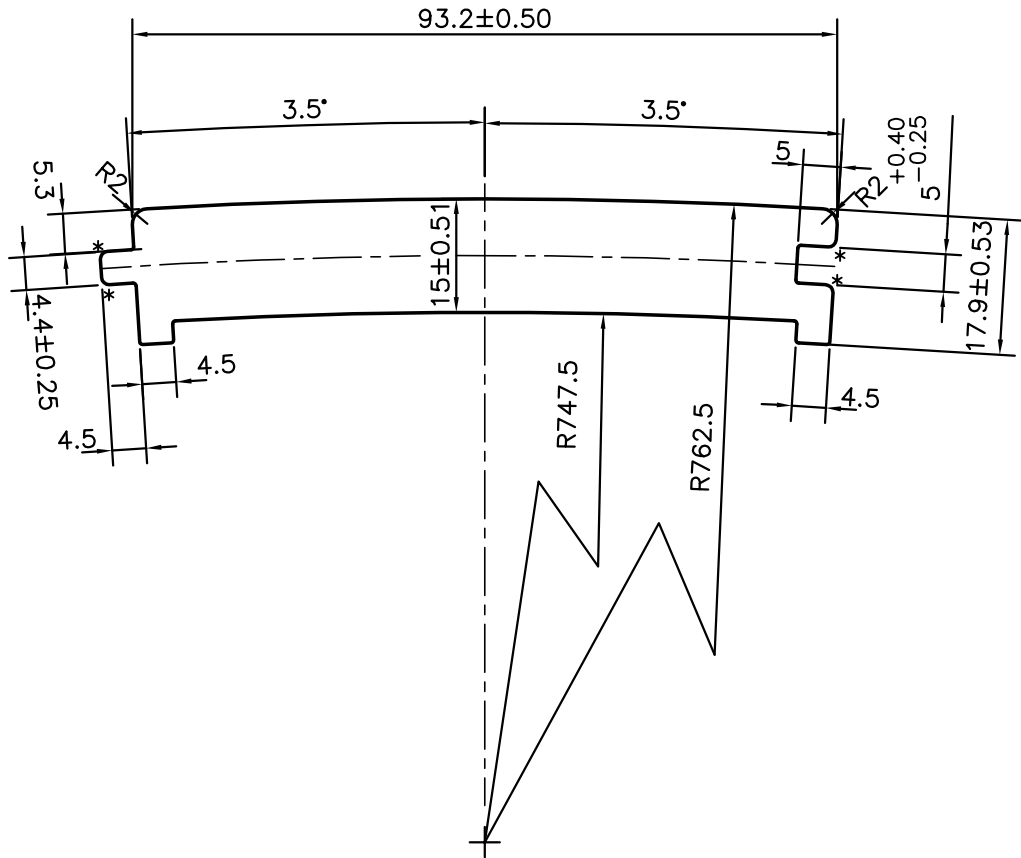

\* = RADIUS 1.0 mm ( 4 PLACES)



SYMBOL OF QUALITY  
AN ISO 9001 COMPANY

**JINDAL ALUMINIUM LTD.**  
BANGALORE-560073 (INDIA)

	NAME	DATE
DRAWN	J.P.KAUSHIK	02-07-2011
CHECKED		
APPROVED	S.S.GARG	09-07-2011
SCALE		1:1
AREA mm <sup>2</sup>		1407.039
PERIMETER mm.		240.589
WEIGHT kg/m		3.799
DRAWING No.	SECTION No.	
P-11058-1	-	
S2996	S2996	
24832	24832	

1. ALL DIMENSIONS ARE IN mm.
2. ROUND OFF ALL SHARP CORNERS WITH 0.40 mm.
3. TOLERANCES WILL BE AS PER, BS:EN-755-9 UNLESS OTHERWISE SPECIFIED

PARTY'S NAME	BAJAJ TAMBULA PINNED PRODUCTS PVT. LTD., KOLKATA
PARTY'S DRAWING No.	BT/BLV/006/11-12
ALLOY & TEMPER	6082 T6
DESCRIPTION	MISC. SECTION