

P-11088-1

S3011

24834

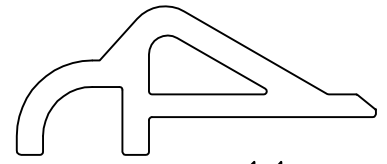

1:1

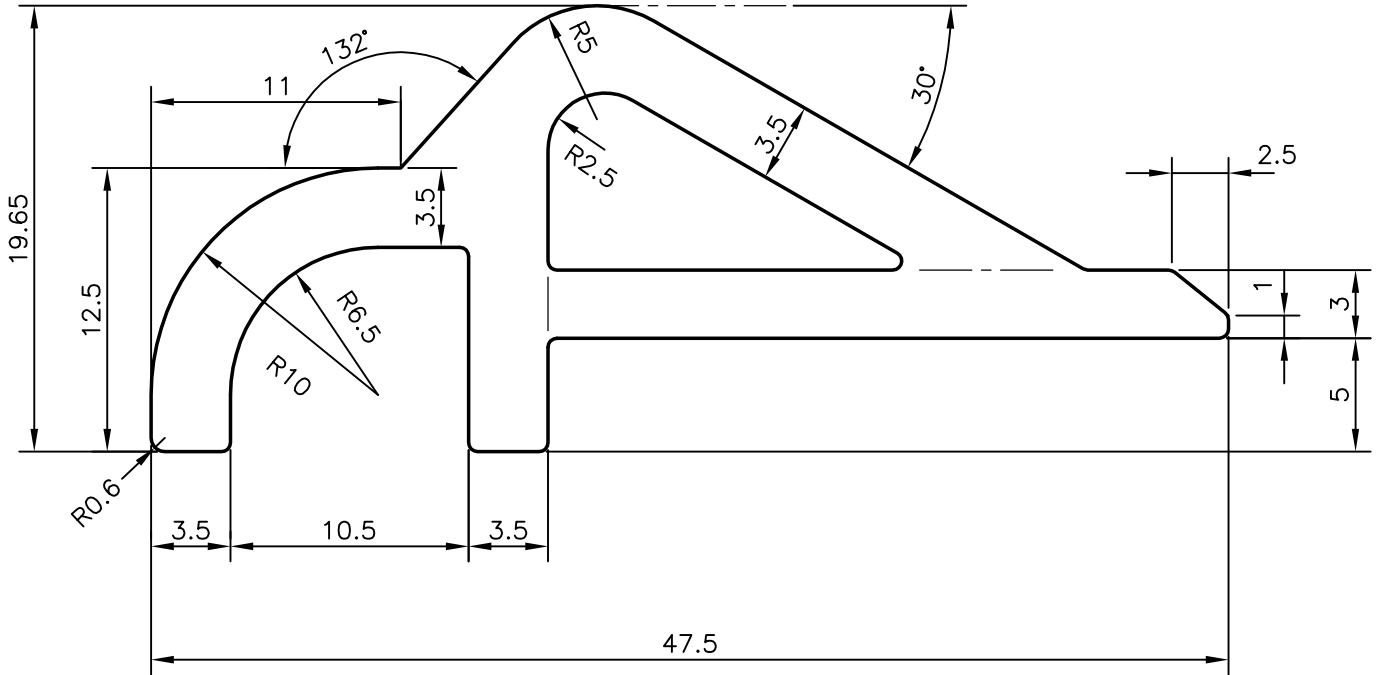

SYMBOL OF QUALITY
AN ISO 9001 COMPANY

JINDAL ALUMINIUM LTD.
BANGALORE-560073 (INDIA)

	NAME	DATE
DRAWN	J.P.KAUSHIK	25-07-2011
CHECKED		
APPROVED	S.S.GARG	27-07-2011
SCALE		3:1
AREA mm ²		304.575
PERIMETER mm.		129.77
WEIGHT kg/m		0.822

1. ALL DIMENSIONS ARE IN mm.
2. ROUND OFF ALL SHARP CORNERS WITH 0.40 mm.
3. TOLERANCES WILL BE AS PER,BS:EN-755-9 UNLESS OTHERWISE SPECIFIED

PARTY'S NAME	TEX-TECH INDUSTRIES (INDIA) LTD., COIMBATORE	DRAWING No.	P-11088-1	SECTION No.	-
PARTY'S DRAWING No.	MODEL :E66	S3011	S3011		
ALLOY & TEMPER	HE9 WP	24834	24834		
DESCRIPTION	TEXTILE SECTION (TOP COMB HOLDER)				