

P-11546

S3176

X1600

24838

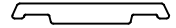

SCALE :- 1:1

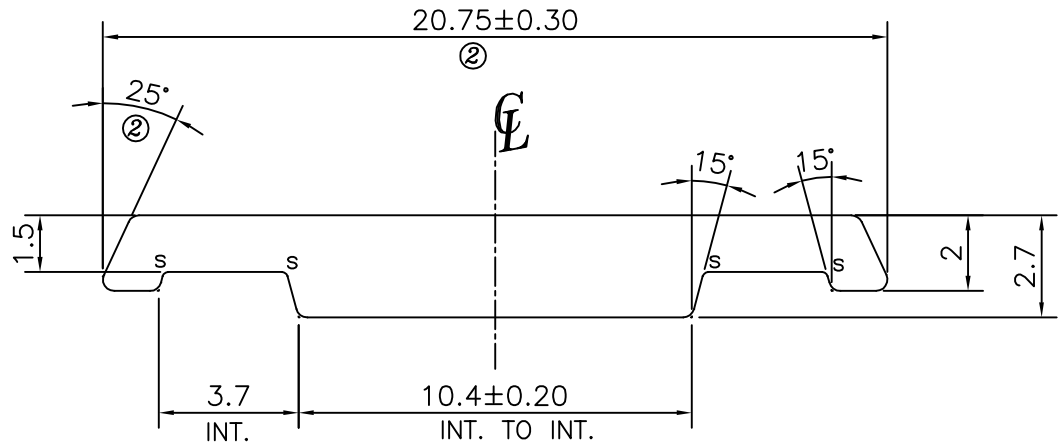

ISSUE (2) :-

1. ANGLE CHANGED FROM 15° TO 25°
2. DIMENSION CHANGED FROM 20±0.3 TO 20.75±0.30
3. WEIGHT ALSO CHANGED FROM 0.117 kg/m TO 0.119 kg/m.

TEWIST & BEND = 1.70 mm./mtr.  
 ROUND OFF ALL SHARP CORNERS WITH 0.30 mm.  
 S = RADIUS 0.15 mm. (4 PLACES)



SYMBOL OF QUALITY  
AN ISO 9001 COMPANY

**JINDAL ALUMINIUM LTD.**  
BANGALORE-560073 (INDIA)

	NAME	DATE
DRAWN	PARVESH	03-01-2013
CHECKED		
APPROVED	S.S.GARG	04-01-2013
SCALE		5:1
AREA mm <sup>2</sup>		44.206
PERIMETER mm.		46.171
WEIGHT kg/m		0.119
DRAWING No.	SECTION No.	
P-11546		
S3176	S3176	
X1600	X1600(ISSUE-2)	
24838	24838	

1. ALL DIMENSIONS ARE IN mm.
2. ROUND OFF ALL SHARP CORNERS WITH 0.30 mm.
3. TOLERANCES WILL BE AS PER IS:3965-1981, UNLESS OTHERWISE SPECIFIED

PARTY'S NAME	SANMIT CARD CLOTHING INDIA PVT. LTD, COIMBATORE
PARTY'S DRAWING No.	SUNMIT-EP-TYPE-C-101
ALLOY & TEMPER	HE9 WP
DESCRIPTION	TEXTILE SECTION