

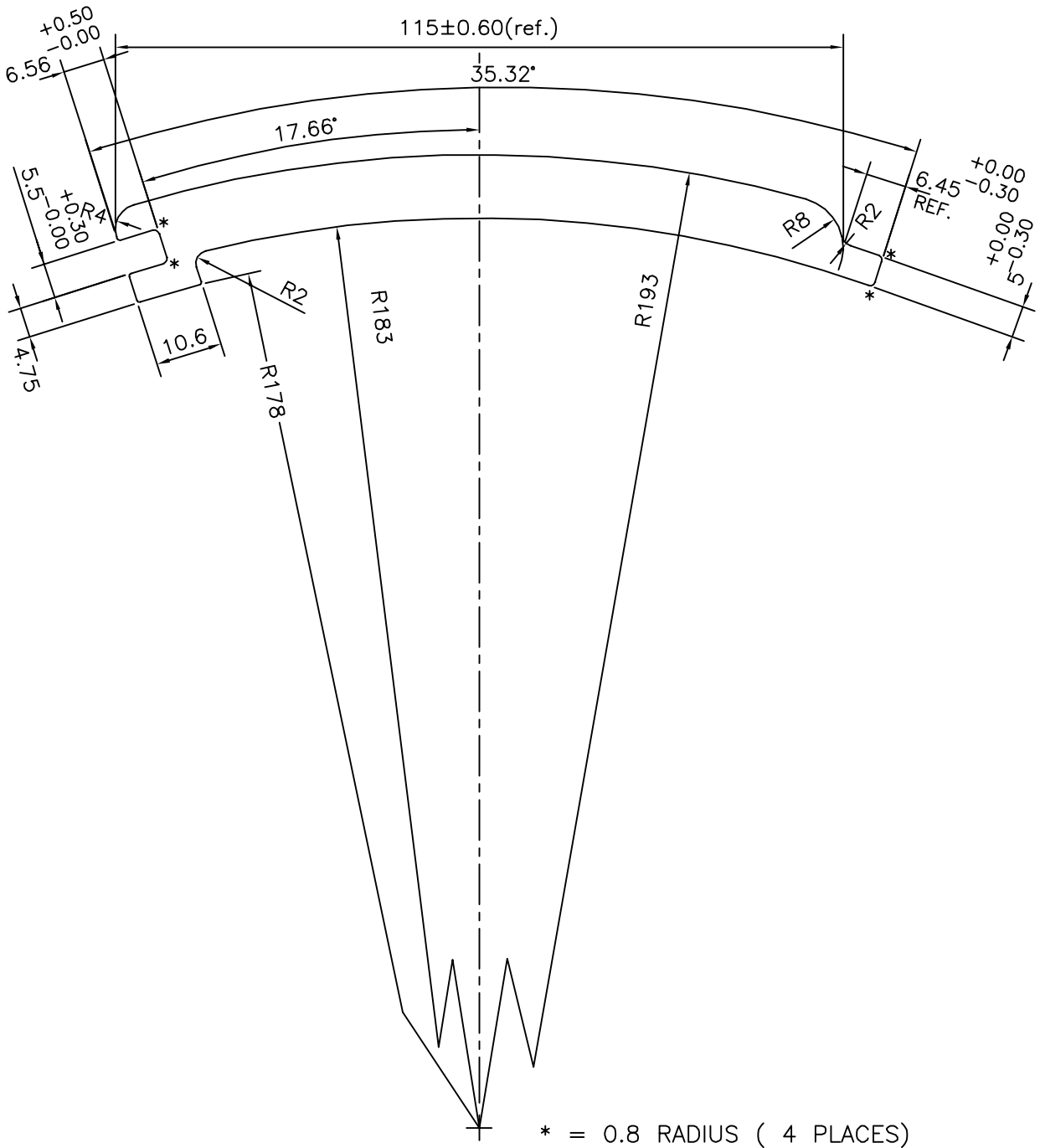

P-12039
S3490
24850



 SYMBOL OF QUALITY AN ISO 9001 COMPANY	<b>JINDAL ALUMINIUM LTD.</b> BANGALORE-560073 (INDIA)	NAME		DATE
		DRAWN	J.P.KAUSHIK	14-09-2012
1. ALL DIMENSIONS ARE IN mm. 2. ROUND OFF ALL SHARP CORNERS WITH 0.40 mm. 3. TOLERANCES WILL BE AS PER, IS:3965-1981 UNLESS OTHERWISE SPECIFIED		CHECKED		
		APPROVED	S.S.GARG	04-10-2012
PARTY'S NAME BAJAJ TAMBULA PINNED PRODUCTS PVT. LTD., KOLKATA		SCALE		1:1
		AREA mm <sup>2</sup>		1200.731
PARTY'S DRAWING No. BT/UF/009/12-13		PERIMETER mm.		281.12
		WEIGHT kg/m		3.242
ALLOY & TEMPER 6082 T6		DRAWING No.		SECTION No.
		P-12039		-
DESCRIPTION MISC. SECTION		S3490		S3490
		24850		24850