

P-12050

S3493

24851

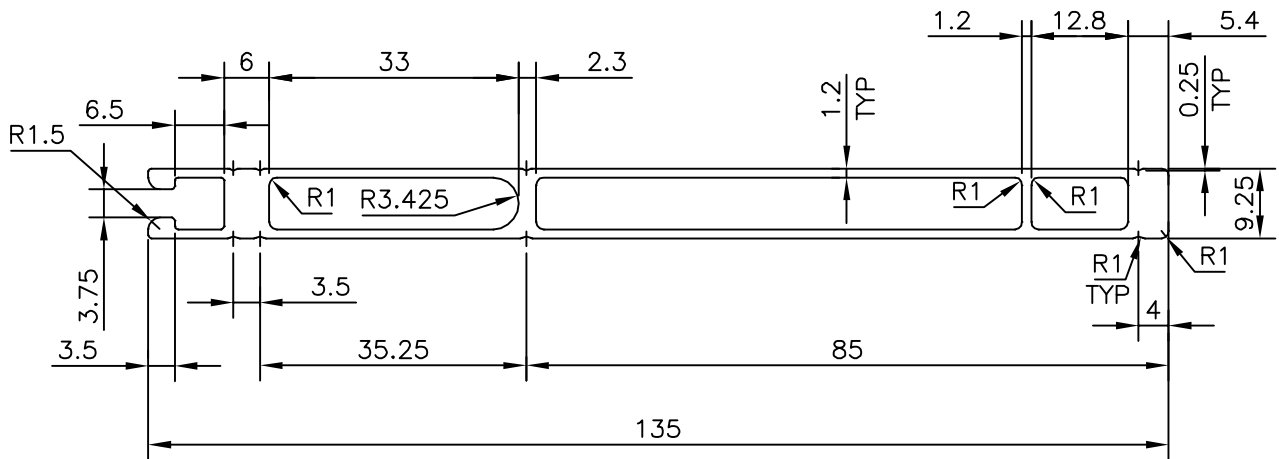

SYMBOL OF QUALITY
AN ISO 9001 COMPANY

JINDAL ALUMINIUM LTD.
BANGALORE-560073 (INDIA)

	NAME	DATE
DRAWN	RAGHAVENDRA	21-09-2012
CHECKED		
APPROVED	S.S.GARG	07-10-2012

1. ALL DIMENSIONS ARE IN mm.
2. ROUND OFF ALL SHARP CORNERS WITH 0.40 mm.
3. TOLERANCES WILL BE AS PER IS:6477-1983 UNLESS OTHERWISE SPECIFIED

SCALE	1:1
AREA mm ²	440.858
PERIMETER mm.	312
WEIGHT kg/m	1.190

PARTY'S NAME MEHUL IRON & STEEL WORKS, MUMBAI

DRAWING No. SECTION No.

PARTY'S DRAWING No. AS PER SAMPLE

P-12050

S3493

24851

-

S3493

24851

ALLOY & TEMPER 63400 WP

DESCRIPTION/END USE TEXTILE MACHINERY SECTION