

P-12240-1

X1649

24856

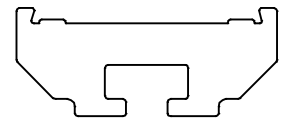
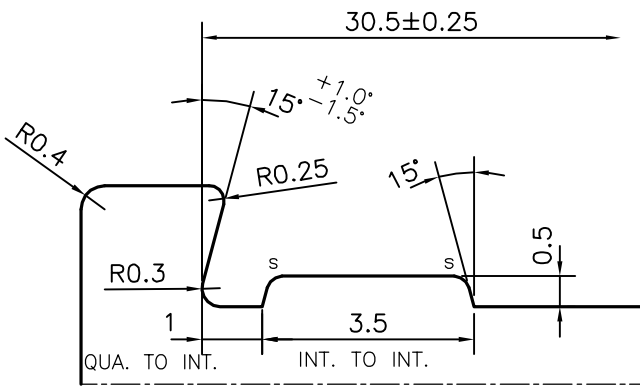

SCALE: - 1:1

DETAIL OF "A"
SCALE :- 8:1

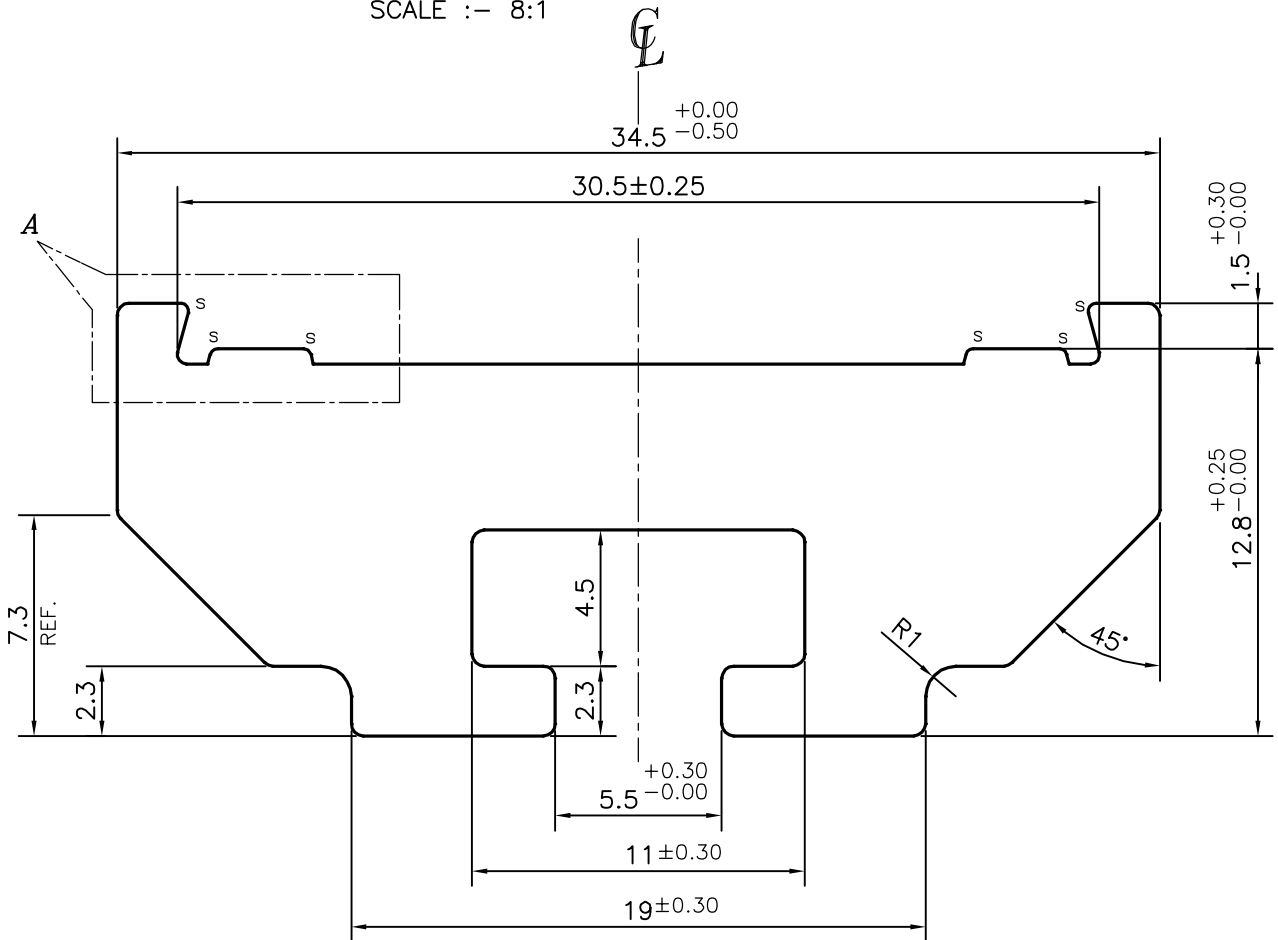

1. TWIST & BEND=1.0mm/M
2. ANGULARITY= ±2°

S = RADIUS 0.25mm (6 PLACES)



SYMBOL OF QUALITY
AN ISO 9001 COMPANY

JINDAL ALUMINIUM LTD.
BANGALORE-560073 (INDIA)

	NAME	DATE
DRAWN	PARVESH	05-01-2013
CHECKED		
APPROVED	S.S.GARG	25-01-2013

1. ALL DIMENSIONS ARE IN mm.
2. ROUND OFF ALL SHARP CORNERS WITH 0.40 mm.
3. TOLERANCES WILL BE AS PER IS:3965-1981 , UNLESS OTHERWISE SPECIFIED

SCALE	4:1
AREA mm ²	313.895
PERIMETER mm.	119.025
WEIGHT kg/m	0.848

PARTY'S NAME	THE INDIAN CARD CLOTHING CO. LTD., PUNE
PARTY'S DRAWING No.	SF-743/E
ALLOY & TEMPER	HE9 WP
DESCRIPTION	TEXTILE SECTION

DRAWING No.	SECTION No.
P-12240-1	-
X1649	X1649
24856	24856