

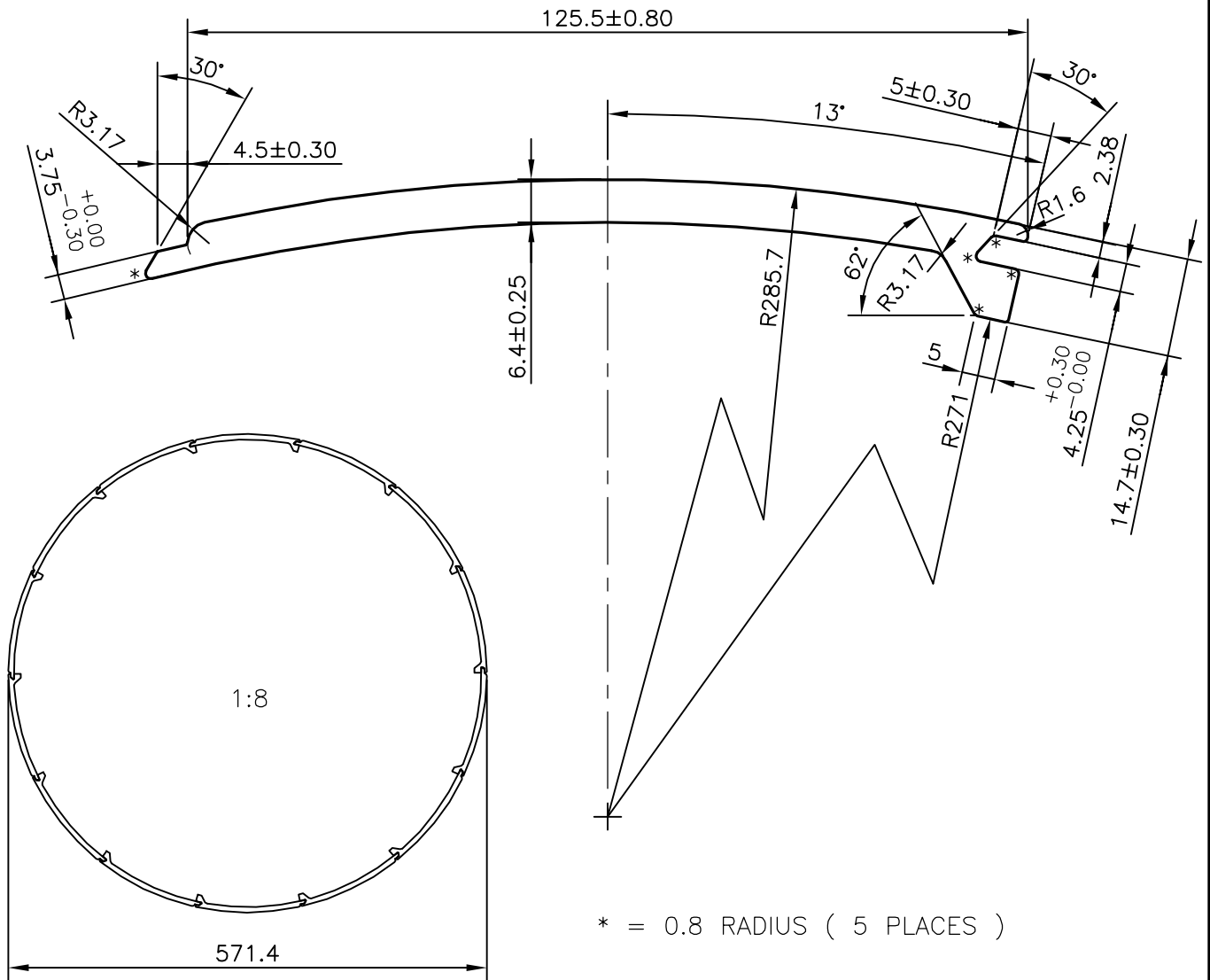

P-12242

S3576

24857



 SYMBOL OF QUALITY AN ISO 9001 COMPANY	<b>JINDAL ALUMINIUM LTD.</b> BANGALORE-560073 (INDIA)	DRAWN	NAME	DATE
		CHECKED	J.P.KAUSHIK	16-11-2012
1. ALL DIMENSIONS ARE IN mm. 2. ROUND OFF ALL SHARP CORNERS WITH 0.40 mm. 3. TOLERANCES WILL BE AS PER, BS:EN-12020-2 UNLESS OTHERWISE SPECIFIED		APPROVED	B.NATARAJA	05-12-2012
		SCALE		1:1
PARTY'S NAME BAJAJ INDUSTRIES PVT.LTD., KOLKATA		AREA	mm <sup>2</sup>	871.884
		PERIMETER	mm.	298.043
PARTY'S DRAWING No. PROV/003/12-13		WEIGHT	kg/m	2.354
		DRAWING No.	SECTION No.	
ALLOY & TEMPER 6082 T6		P-12242	-	
		S3576	S3576	
DESCRIPTION MISC. SECTION		24857	24857	