

P-14659

24864

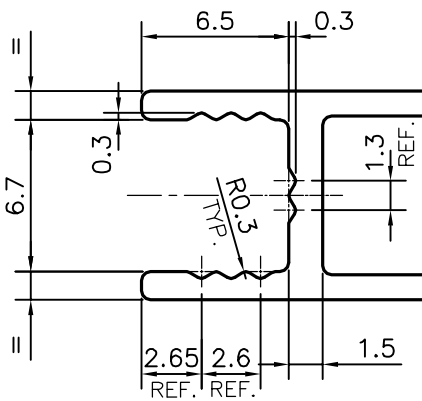

DETAIL OF "A"
SCALE 3:1

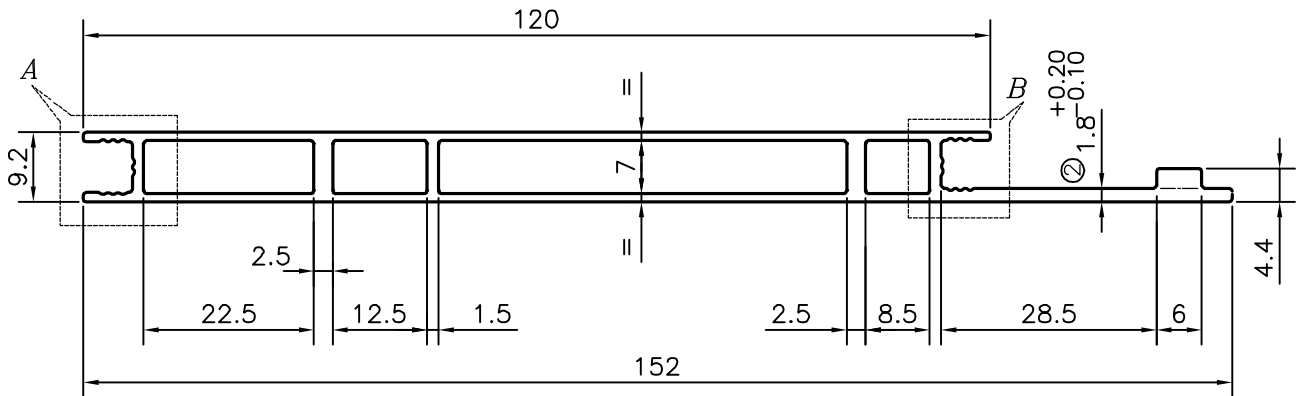
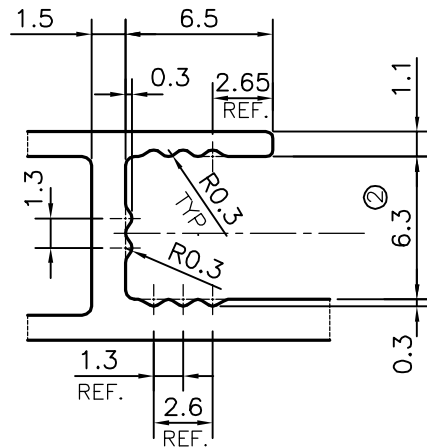

DETAIL OF "B"
SCALE 3:1

ISSUE-2

DIMENSION CHANGED FROM 6.7 mm TO 6.3 mm
THICKNESS CHANGED FROM 1.4 mm TO 1.8 mm
& TOLERANCE ADDED

WEIGHT ALSO CHANGED FROM 1.067 TO 1.102 kg/m

TOLERANCES ON OVERALL WIDTHS & WIDTHS ACROSS FLATS OF BARS, & REGULAR SECTIONS

UPTO 6.40mm - ±0.20	UPTO 32.0mm - ±0.38	UPTO 120.0mm - ±0.85	1. STRAIGHTNESS=1.7mm/M 2. TWIST=1.7mm/M 3. ANGULARITY= ±2° 4. FLATNESS =0.007xWIDTH
UPTO 10.0mm - ±0.23	UPTO 50.0mm - ±0.46	UPTO 160.0mm - ±1.02	
UPTO 12.0mm - ±0.25	UPTO 60.0mm - ±0.53	UPTO 200.0mm - ±1.14	
UPTO 16.0mm - ±0.28	UPTO 80.0mm - ±0.69	UPTO 250.0mm - ±1.40	
UPTO 25.0mm - ±0.30	UPTO 100.0mm - ±0.75	UPTO 300.0mm - ±1.65	



SYMBOL OF QUALITY
AN ISO 9001 COMPANY

JINDAL ALUMINIUM LTD.
BANGALORE-560073 (INDIA)

	NAME	DATE
DRAWN	J.P.KAUSHIK	19-04-2018
CHECKED		
APPROVED	B.NATARAJA	23-04-2018
SCALE		1:1
AREA mm ²		408.301
PERIMETER mm.		353.018
WEIGHT kg/m		1.102
DRAWING No.	SECTION No.	
P-14659	-	
24864	24864(ISSUE-2)	

1. ALL DIMENSIONS ARE IN mm.
2. ROUND OFF ALL SHARP CORNERS WITH 0.40 mm.
3. TOLERANCES WILL BE AS PER IS:6477-1983 , UNLESS OTHERWISE SPECIFIED

PARTY'S NAME	GENERAL CATEGORY, MUMBAI MARKET
PARTY'S DRAWING No.	AS PER DRAWING
ALLOY & TEMPER	HE9 WP
DESCRIPTION	TEXTILE SECTION