

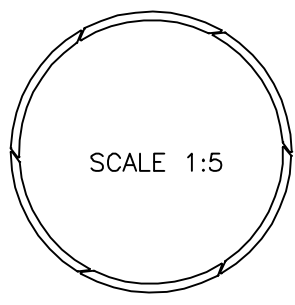

P-12996
S3857
24869

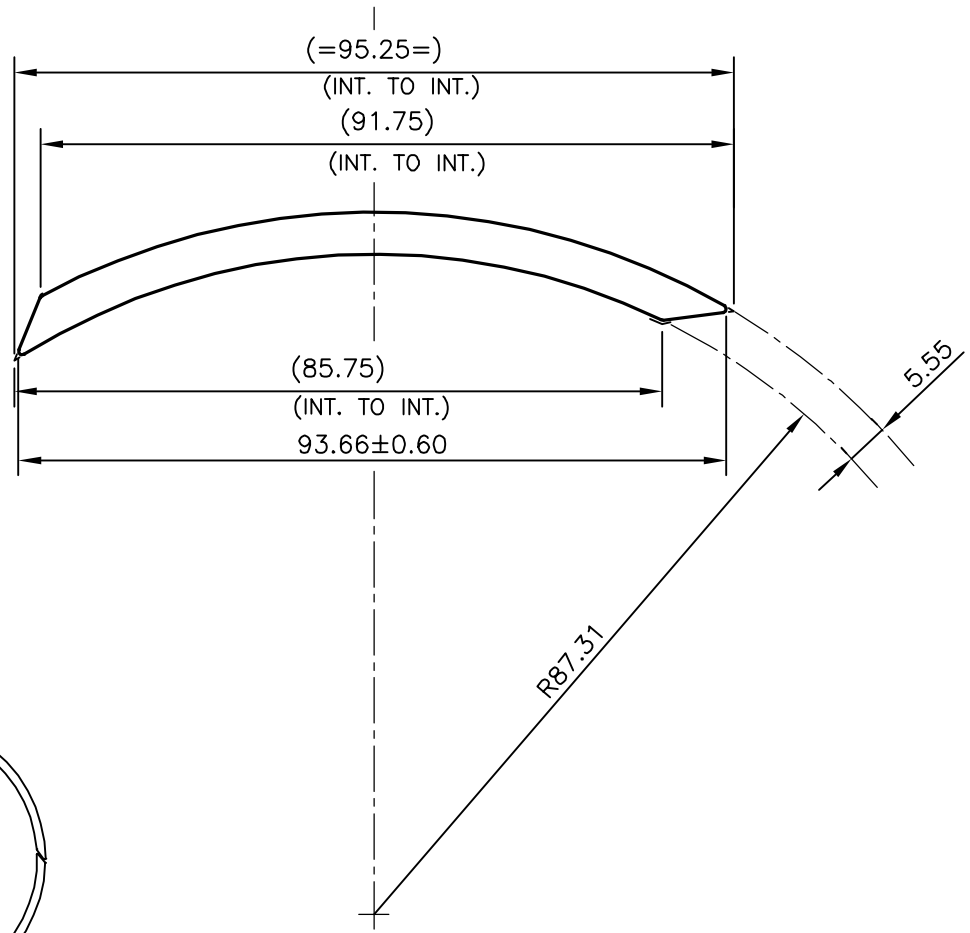

6 NO. OF PIECES

TOLERANCES ON OVERALL WIDTHS & WIDTHS ACROSS FLATS OF BARS, & REGULAR SECTIONS

UPTO 6.40mm - ±0.20	UPTO 32.0mm - ±0.38	UPTO 120.0mm - ±0.85	UPTO 320.00mm - ±1.70
UPTO 10.0mm - ±0.23	UPTO 50.0mm - ±0.46	UPTO 160.0mm - ±1.02	
UPTO 12.0mm - ±0.25	UPTO 60.0mm - ±0.53	UPTO 200.0mm - ±1.14	
UPTO 16.0mm - ±0.28	UPTO 80.0mm - ±0.69	UPTO 250.0mm - ±1.40	
UPTO 25.0mm - ±0.30	UPTO 100.0mm - ±0.75	UPTO 300.0mm - ±1.65	

 SYMBOL OF QUALITY AN ISO 9001 COMPANY	JINDAL ALUMINIUM LTD. BANGALORE-560073 (INDIA)	DRAWN	NAME	DATE	
		CHECKED	SRIYATHSA	02-09-2013	
1. ALL DIMENSIONS ARE IN mm. 2. ROUND OFF ALL SHARP CORNERS WITH 0.50 mm. 3. TOLERANCES WILL BE AS PER IS:3965-1981 , UNLESS OTHERWISE SPECIFIED		APPROVED	S.S.GARG	10-09-2013	
		SCALE		1:1	
PARTY'S NAME		BAJAJ INDUSTRIES PVT. LTD., KOLKATA		AREA mm ²	514.803
		PARTY'S DRAWING No.		BI/MK/012/13-14	PERIMETER mm.
ALLOY & TEMPER		6082 T6		WEIGHT kg/m	1.390
		DESCRIPTION		TEXTILE SECTION	DRAWING No.
				P-12996	-
				S3857	S3857
				24869	24869