

P-12994

S3855

24871

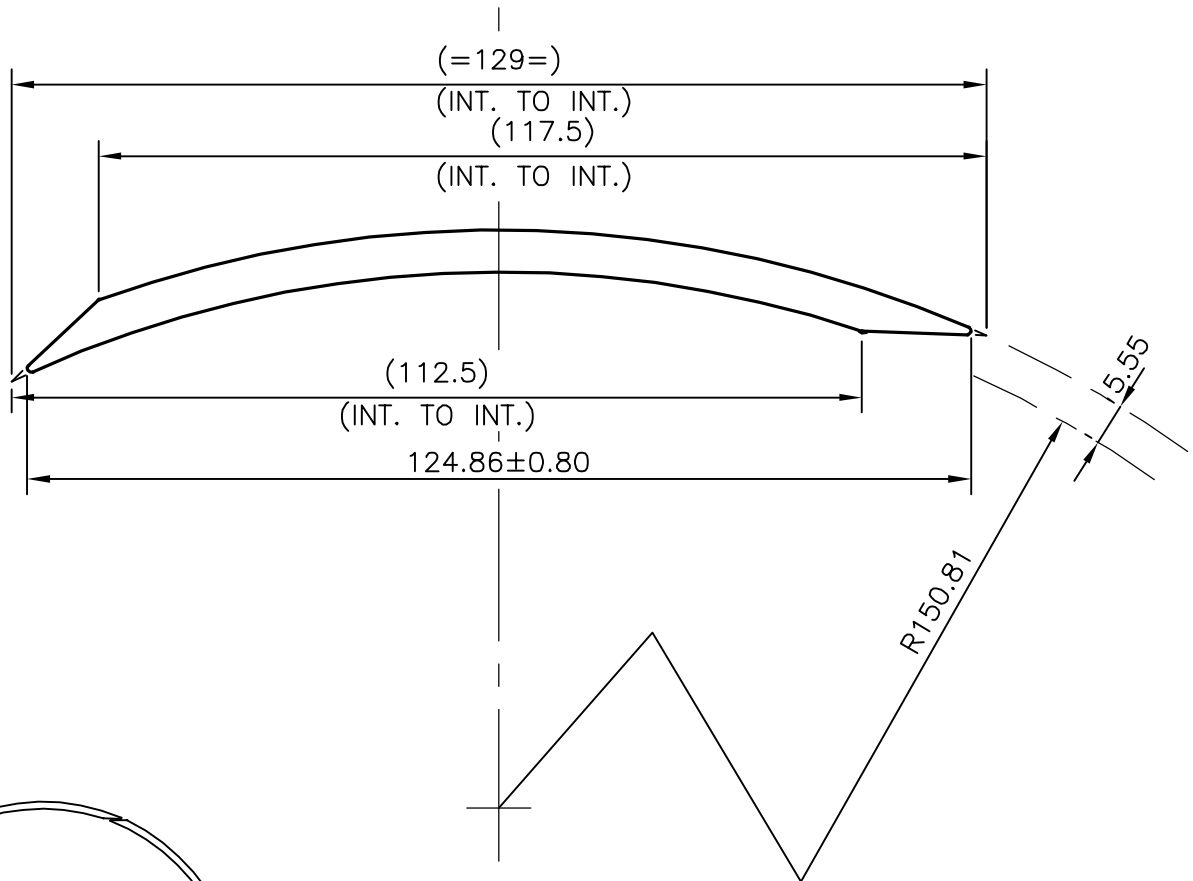

8 NO. OF PIECES

TOLERANCES ON OVERALL WIDTHS & WIDTHS ACROSS FLATS OF BARS, & REGULAR SECTIONS

| | | | |
|---------------------|----------------------|----------------------|-----------------------|
| UPTO 6.40mm - ±0.20 | UPTO 32.0mm - ±0.38 | UPTO 120.0mm - ±0.85 | UPTO 320.00mm - ±1.70 |
| UPTO 10.0mm - ±0.23 | UPTO 50.0mm - ±0.46 | UPTO 160.0mm - ±1.02 | |
| UPTO 12.0mm - ±0.25 | UPTO 60.0mm - ±0.53 | UPTO 200.0mm - ±1.14 | |
| UPTO 16.0mm - ±0.28 | UPTO 80.0mm - ±0.69 | UPTO 250.0mm - ±1.40 | |
| UPTO 25.0mm - ±0.30 | UPTO 100.0mm - ±0.75 | UPTO 300.0mm - ±1.65 | |



SYMBOL OF QUALITY
AN ISO 9001 COMPANY

JINDAL ALUMINIUM LTD.
BANGALORE-560073 (INDIA)

| | NAME | DATE |
|----------|-----------|------------|
| DRAWN | SRIVATHSA | 02-09-2013 |
| CHECKED | | |
| APPROVED | S.S.GARG | 10-09-2013 |

1. ALL DIMENSIONS ARE IN mm.
2. ROUND OFF ALL SHARP CORNERS WITH 0.50 mm.
3. TOLERANCES WILL BE AS PER IS:3965-1981 , UNLESS OTHERWISE SPECIFIED

| | |
|----------------------|---------|
| SCALE | 1:1 |
| AREA mm ² | 653.227 |
| PERIMETER mm. | 259.812 |
| WEIGHT kg/m | 1.764 |

PARTY'S NAME BAJAJ INDUSTRIES PVT. LTD., KOLKATA

PARTY'S DRAWING No. BI/MK/013/13-14

ALLOY & TEMPER 6082 T6

DESCRIPTION TEXTILE SECTION

| DRAWING No. | SECTION No. |
|-------------|-------------|
| P-12994 | - |
| S3855 | S3855 |
| 24871 | 24871 |