

P-12995

S3856

24872

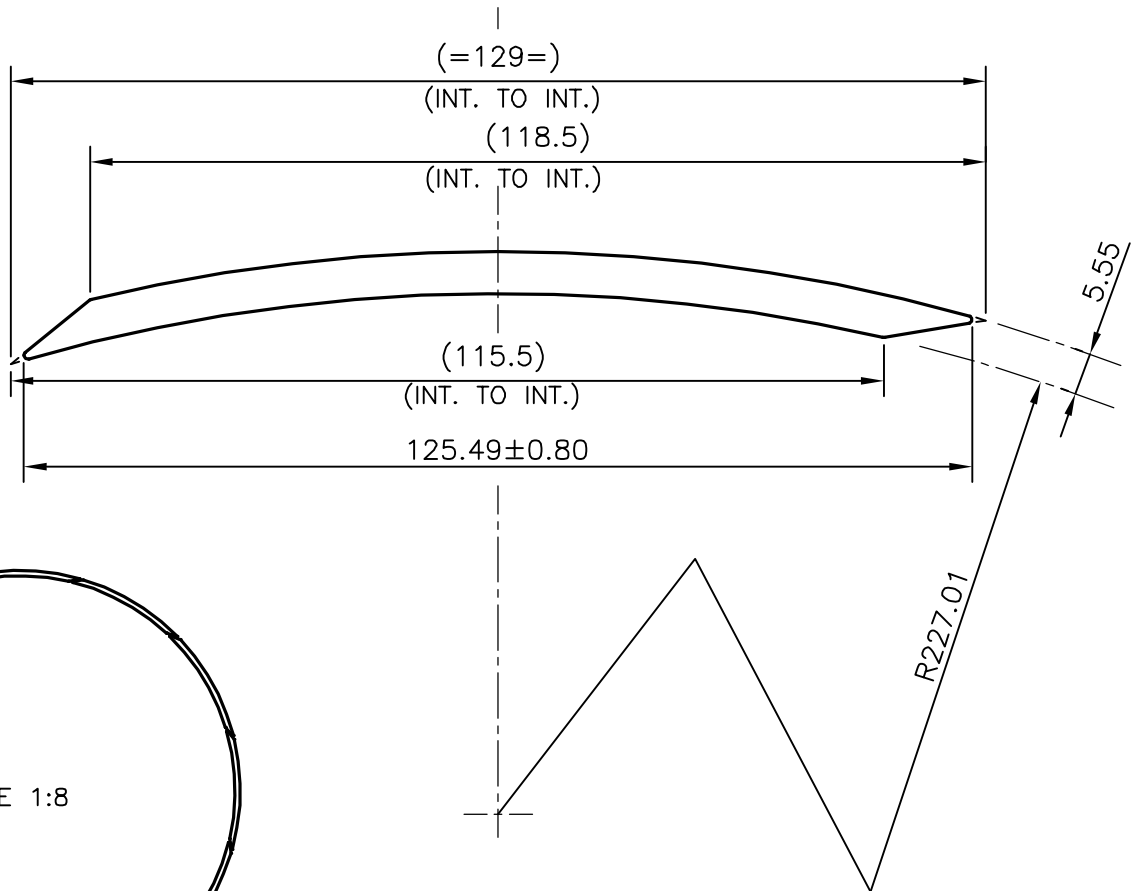

12 NO. OF PIECES

TOLERANCES ON OVERALL WIDTHS & WIDTHS ACROSS FLATS OF BARS, & REGULAR SECTIONS

UPTO 6.40mm - ±0.20	UPTO 32.0mm - ±0.38	UPTO 120.0mm - ±0.85	UPTO 320.00mm - ±1.70
UPTO 10.0mm - ±0.23	UPTO 50.0mm - ±0.46	UPTO 160.0mm - ±1.02	
UPTO 12.0mm - ±0.25	UPTO 60.0mm - ±0.53	UPTO 200.0mm - ±1.14	
UPTO 16.0mm - ±0.28	UPTO 80.0mm - ±0.69	UPTO 250.0mm - ±1.40	
UPTO 25.0mm - ±0.30	UPTO 100.0mm - ±0.75	UPTO 300.0mm - ±1.65	



SYMBOL OF QUALITY
AN ISO 9001 COMPANY

JINDAL ALUMINIUM LTD.
BANGALORE-560073 (INDIA)

	NAME	DATE
DRAWN	SRIVATHSA	02-09-2013
CHECKED		
APPROVED	S.S.GARG	10-09-2013

1. ALL DIMENSIONS ARE IN mm.
2. ROUND OFF ALL SHARP CORNERS WITH 0.50 mm.
3. TOLERANCES WILL BE AS PER IS:3965-1981 , UNLESS OTHERWISE SPECIFIED

SCALE	1:1
AREA mm ²	655.184
PERIMETER mm.	257.235
WEIGHT kg/m	1.769

PARTY'S NAME BAJAJ INDUSTRIES PVT. LTD., KOLKATA

PARTY'S DRAWING No. BI/MK/011/13-14

ALLOY & TEMPER 6082 T6

DESCRIPTION TEXTILE SECTION

DRAWING No.	SECTION No.
P-12995	-
S3856	S3856
24872	24872