

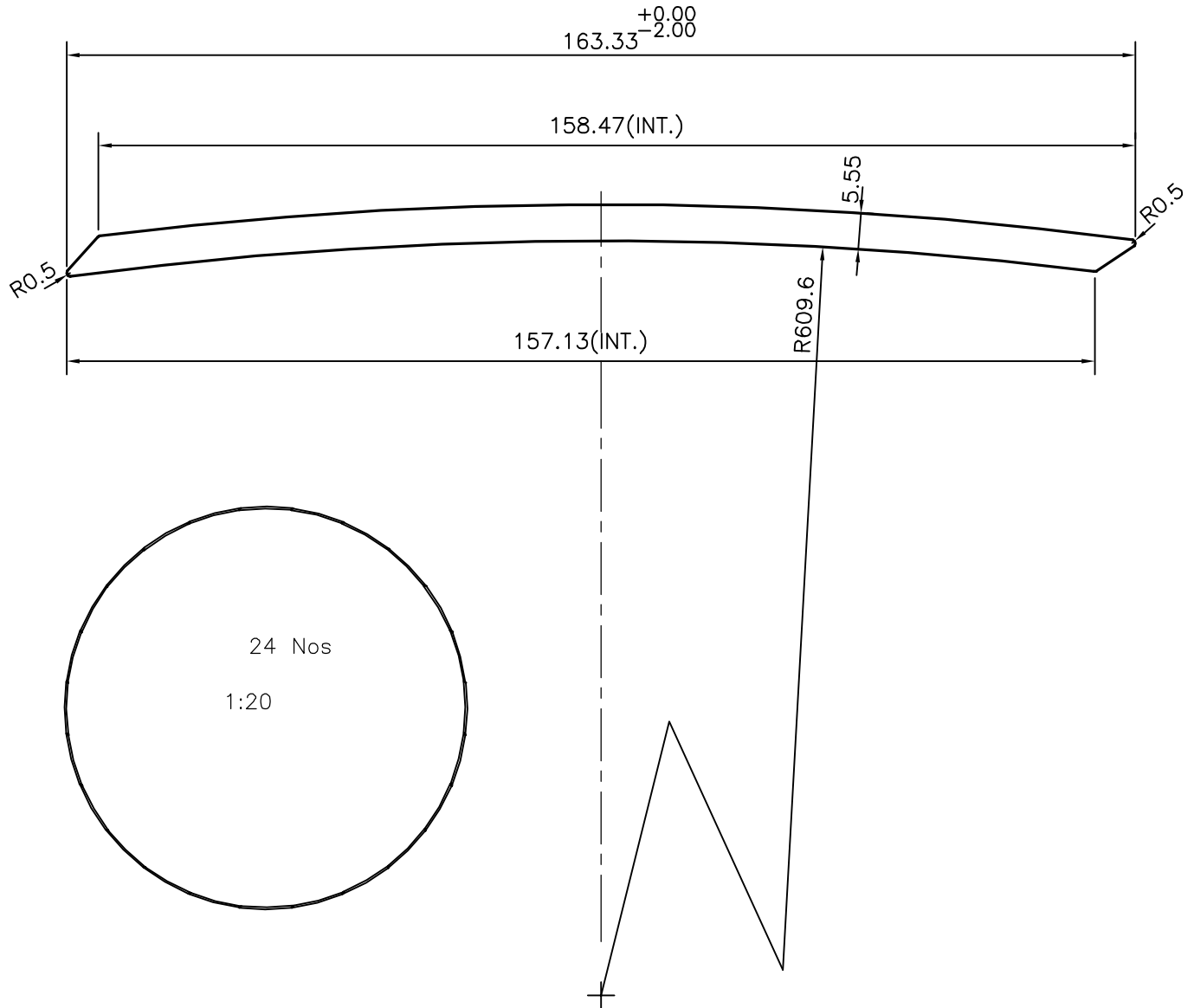

| |
|-----------|
| P-13097-1 |
| S3948 |
| 24875 |



PLEASE SPECIFY THE EXPOSED SURFACE IN THE DRAWING WHEREVER BETTER FINISH REQUIRED.

TOLERANCES ON OVERALL WIDTHS & WIDTHS ACROSS FLATS OF BARS, & REGULAR SECTIONS

| | | | |
|---------------------|----------------------|----------------------|-----------------------|
| UPTO 6.40mm - ±0.20 | UPTO 32.0mm - ±0.38 | UPTO 120.0mm - ±0.85 | UPTO 320.00mm - ±1.70 |
| UPTO 10.0mm - ±0.23 | UPTO 50.0mm - ±0.46 | UPTO 160.0mm - ±1.02 | |
| UPTO 12.0mm - ±0.25 | UPTO 60.0mm - ±0.53 | UPTO 200.0mm - ±1.14 | |
| UPTO 16.0mm - ±0.28 | UPTO 80.0mm - ±0.69 | UPTO 250.0mm - ±1.40 | |
| UPTO 25.0mm - ±0.30 | UPTO 100.0mm - ±0.75 | UPTO 300.0mm - ±1.65 | |

| | | | | | |
|--|--|----------------------|-------------|-------------|------------|
|  SYMBOL OF QUALITY AN ISO 9001 COMPANY | JINDAL ALUMINIUM LTD. BANGALORE-560073 (INDIA) | DRAWN | J.P.KAUSHIK | DATE | 07-12-2013 |
| | | CHECKED | | | |
| 1. ALL DIMENSIONS ARE IN mm. 2. ROUND OFF ALL SHARP CORNERS WITH 0.40 mm. 3. TOLERANCES WILL BE AS PER IS:3965-1981 UNLESS OTHERWISE SPECIFIED | | APPROVED | S.S.GARG | | 16-12-2013 |
| | | SCALE | | | 1:1 |
| PARTY'S NAME BAJAJ INDUSTRIES PVT. LTD., KOLKATA | | AREA mm ² | | | 882.15 |
| | | PERIMETER mm. | | | 332.16 |
| PARTY'S DRAWING No. BI/MK/014/13-14 | | WEIGHT kg/m | | | 2.382 |
| | | DRAWING No. | P-13097-1 | SECTION No. | - |
| ALLOY & TEMPER 6082 T6 | | | S3948 | | S3948 |
| | | | 24875 | | 24875 |
| DESCRIPTION MISC. SECTION | | | | | |
| | | | | | |