

P-13868

S4274

24888

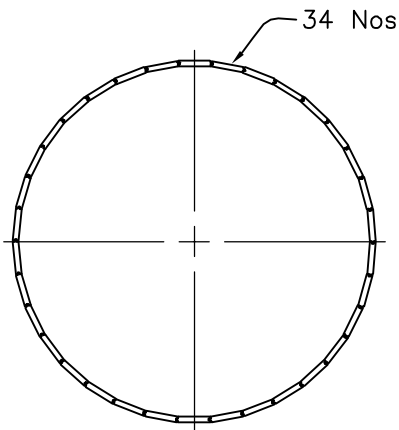
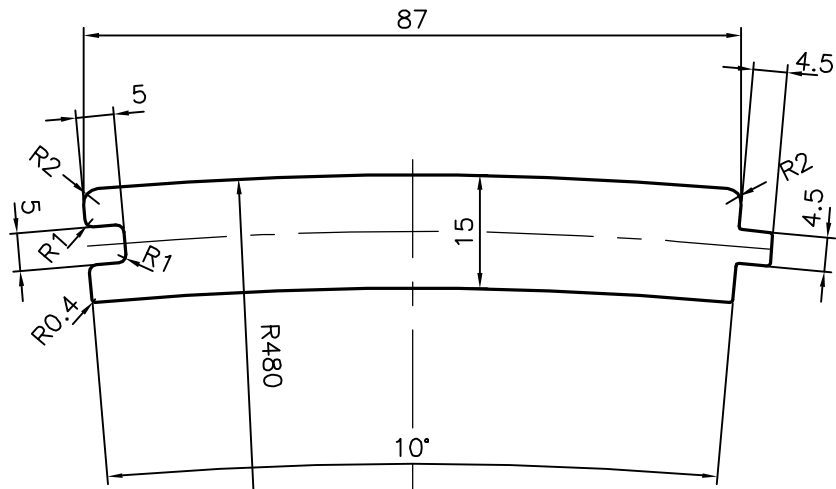

**JINDAL ALUMINIUM LTD.**  
BANGALORE-560073 (INDIA)

	NAME	DATE
DRAWN	J.P.KAUSHIK	11-08-2014
CHECKED		
APPROVED	S.S.CARG	30-10-2014

1. ALL DIMENSIONS ARE IN mm.
2. ROUND OFF ALL SHARP CORNERS WITH 0.40 mm.
3. TOLERANCES WILL BE AS PER IS:3965-1981 , UNLESS OTHERWISE SPECIFIED

SCALE	1:1
AREA mm <sup>2</sup>	1285.639
PERIMETER mm.	216.831
WEIGHT kg/m	3.471

PARTY'S NAME	BAJAJ TAMBULA PINNED PRODUCTS PVT. LTD, KOLKATA
PARTY'S DRAWING No.	BT/LR/016/14-15
ALLOY & TEMPER	6082 T6
DESCRIPTION	LAROCH INTERLOCK SECTION

DRAWING No.	SECTION No.
P-13868	-
S4274	S4274
24888	24888