

7364

25060

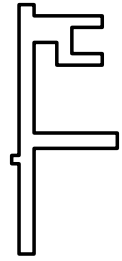

ACTUAL SIZE

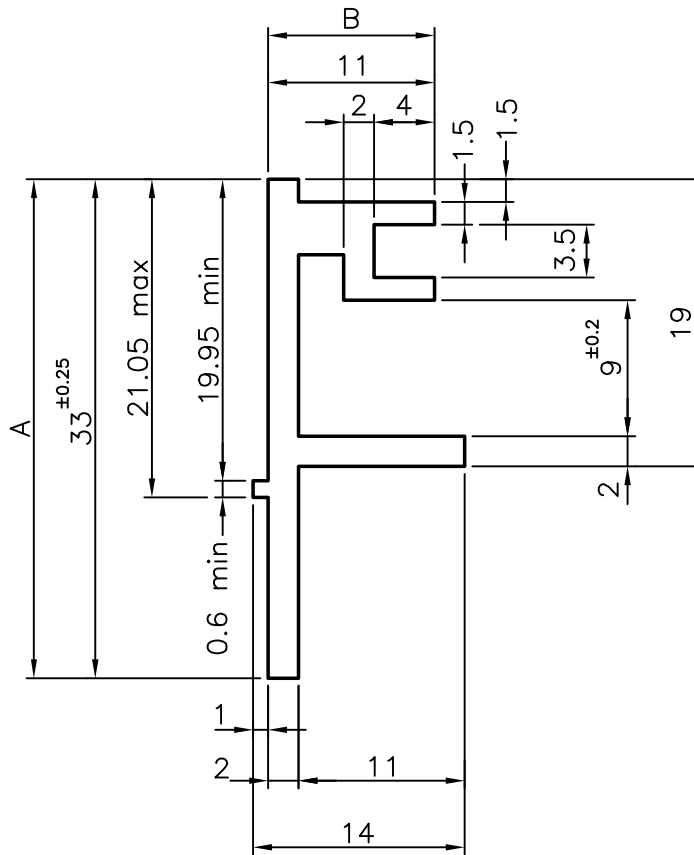

NOTE:—

1. FACES 'A' & 'B' ARE THE VISIBLE FACES ON THE COMPLETED ARTICLE. THEREFORE PACKING PROTECTION WILL BE NECESSARY TO PREVENT SCUFFING & FRETING IN TRANSIT.
2. THIS DRG. SUPERSEDES OF THEIR DRG. No.409A19023. REV H4/25.11.80



SYMBOL OF QUALITY
AN ISO 9002 COMPANY

JINDAL ALUMINIUM LTD.
BANGALORE-560073 (INDIA)

	NAME	DATE
DRAWN	R.D.SHARMA	16.9.87
CHECKED		
APPROVED		
SCALE	2:1	
WEIGHT kg/m	0.336	
SECTION No.	XXXX 25060	
DRAWING No.	25060	

1. ALL DIMENSIONS ARE IN MM
2. ROUND OFF SHARP CORNERS WITH 0.4mm R
3. UNSPECIFIED DIMENSIONAL TOLERANCES WILL BE AS PER IS: 3965-1981.

PARTY'S NAME	EASUN REYROLLE		
PARTY'S DRAWING No.	409A19023 (H)	FINISH	
ALLOY & TEMPER	HE 9 WP	LENGTH:	3658 mm
DESCRIPTION	VERTICAL EXTRUSION		