

P-2959  
7429  
25100

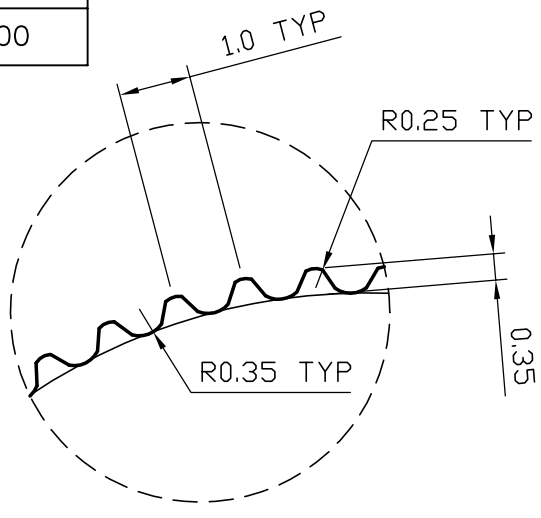

**DETAIL-Z**  
**SCALE 10:1**

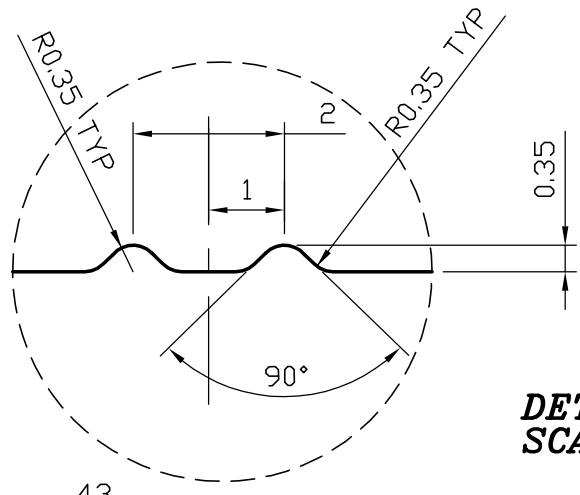

**DETAIL-X**  
**SCALE 10:1**

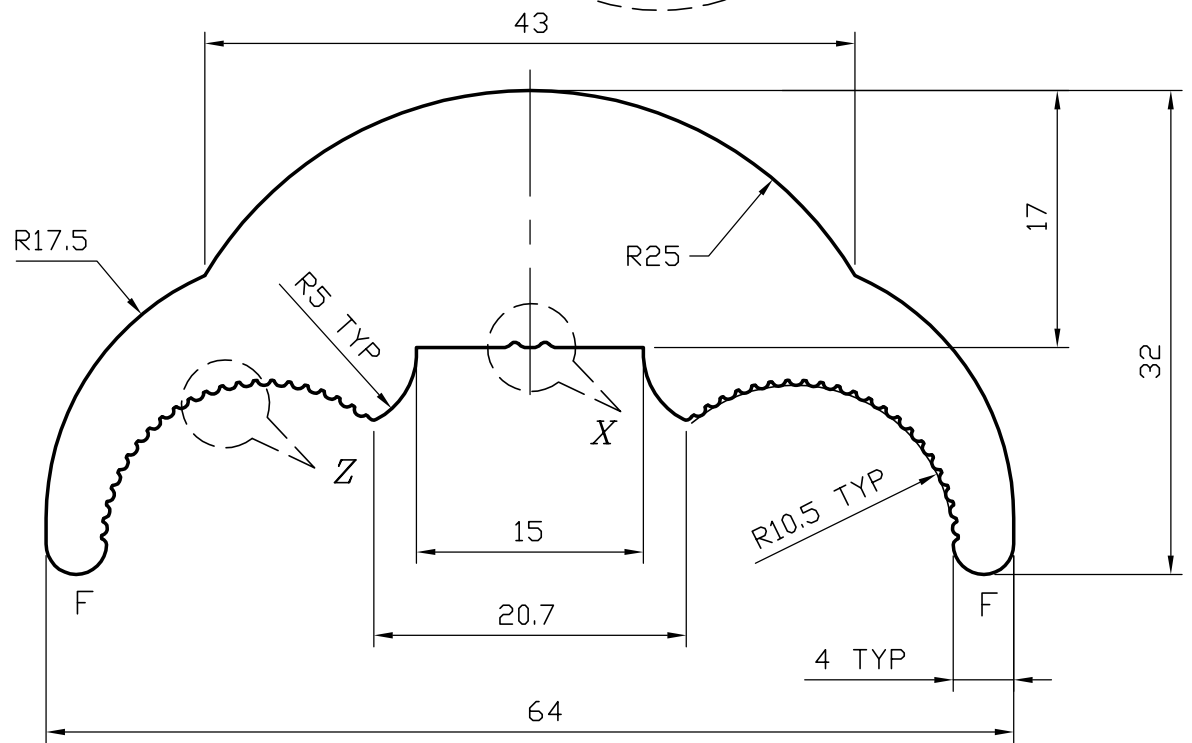
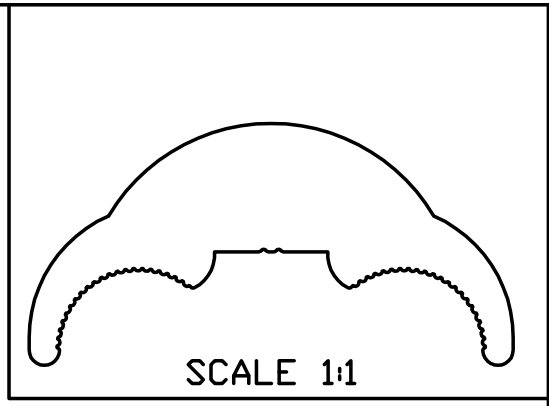

**JINDAL ALUMINIUM LTD.**  
**BANGALORE-560073 (INDIA)**

	NAME	DATE
DRAWN	RANGASWAMY	4-11-2K
CHECKED		
APPROVED		

1. ALL DIMENSIONS ARE IN mm.
2. ROUND OFF ALL SHARP CORNERS WITH 0.40 mm.
3. TOLERANCES WILL BE AS PER I.S.3965-1981 UNLESS OTHERWISE SPECIFIED

PARTY'S NAME	NATIONAL ELECTRICAL INDUSTRIES CO. L.L.C
PARTY'S DRAWING No.	AS PER SAMPLE
ALLOY & TEMPER	HE9 WP
DESCRIPTION	PANEL ACCESSORIES

SCALE	2:1
WEIGHT kg/m	2.325
SECTION No.	25100
DRAWING No.	25100