

P-7716

25145

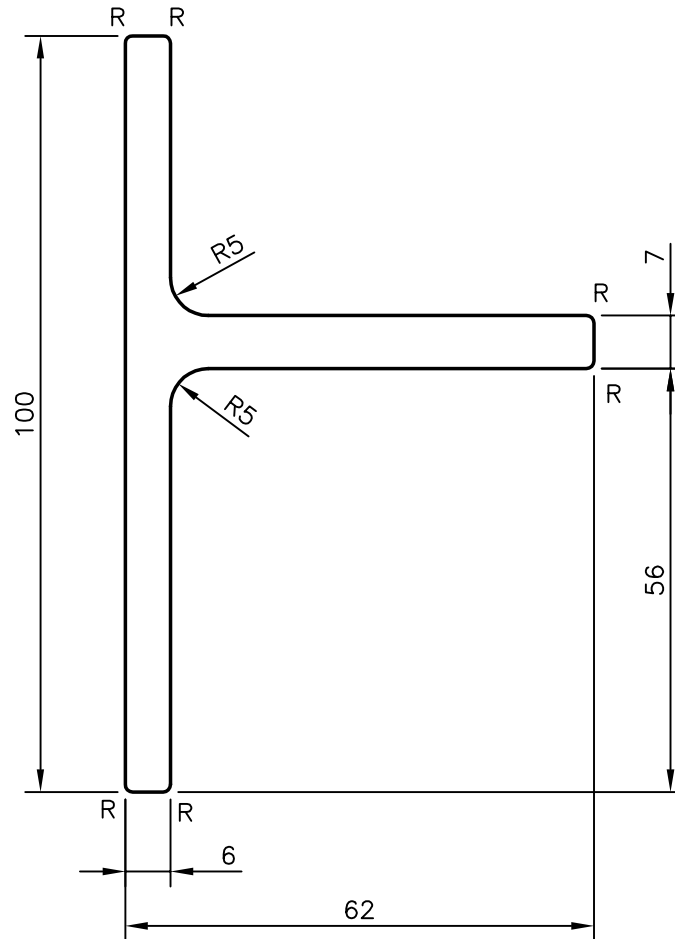

R = R1.0 mm (6 PLACES)



SYMBOL OF QUALITY
AN ISO 9001 COMPANY

JINDAL ALUMINIUM LTD.
BANGALORE-560073 (INDIA)

	NAME	DATE
DRAWN	PRASANN.H	05-12-2007
CHECKED		
APPROVED		
SCALE		1:1
AREA mm ²		1001.442
PERIMETER mm.		317.133
WEIGHT kg/m		2.704
DRAWING No.	SECTION No.	
P-7716	-	
25145	25145	

1. ALL DIMENSIONS ARE IN mm.
2. ROUND OFF ALL SHARP CORNERS WITH 0.40 mm.
3. TOLERANCES WILL BE AS PER IS:3965-1981 UNLESS OTHERWISE SPECIFIED

PARTY'S NAME	NARMADA SWITCHGEAR PVT. LTD., BHOPAL
PARTY'S DRAWING No.	ENQA 4031271 SHEET4
ALLOY & TEMPER	6082 T6
DESCRIPTION	TEE SECTION-MISC.