

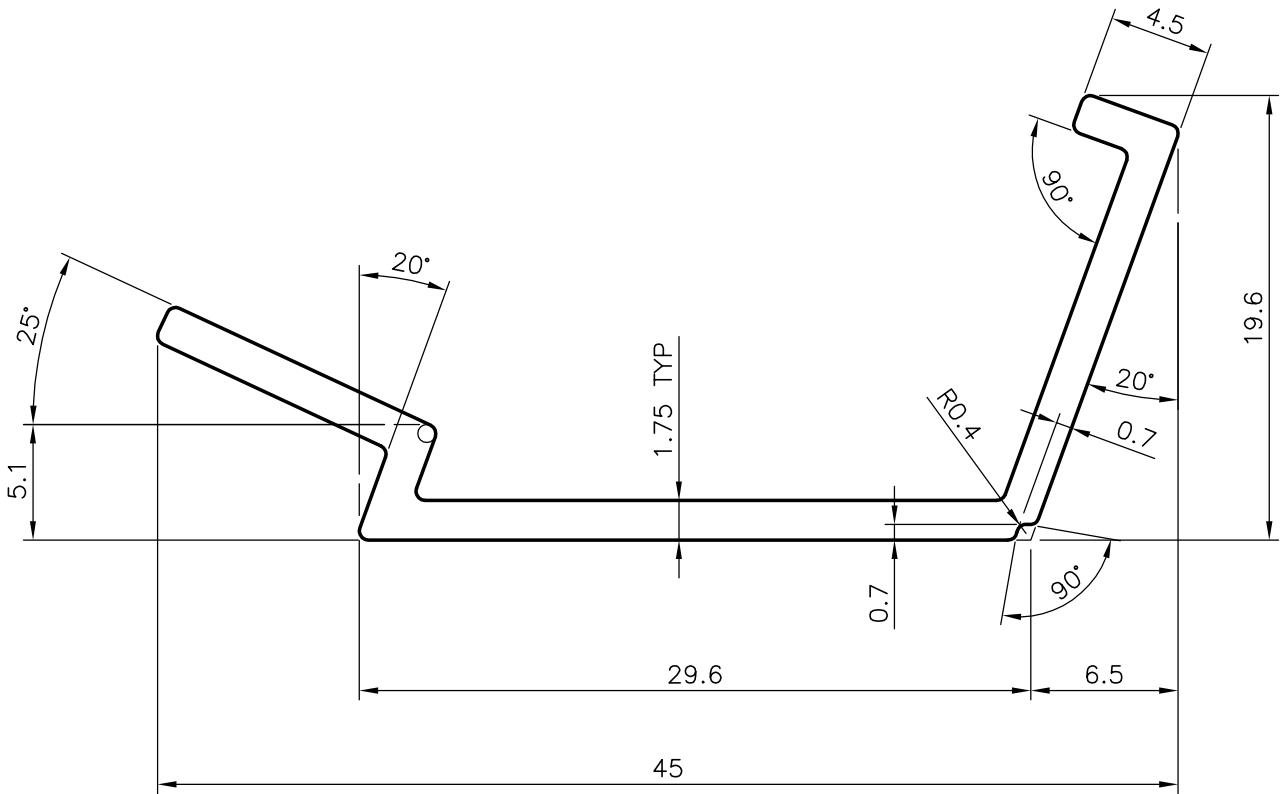

P-5901
S1620
25148

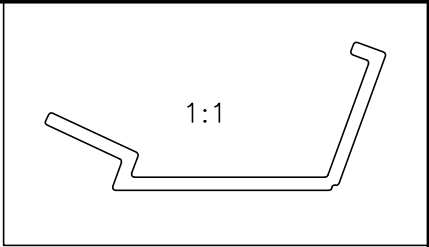

GENERAL WALL THICKNESS = 1.75 mm

 SYMBOL OF QUALITY AN ISO 9001 COMPANY	JINDAL ALUMINIUM LTD. BANGALORE-560073 (INDIA)	NAME		DATE
		DRAWN	MALINGAPPA	06-10-2005
1. ALL DIMENSIONS ARE IN mm. 2. ROUND OFF ALL SHARP CORNERS WITH 0.40 mm. 3. TOLERANCES WILL BE AS PER IS:3965-1981 UNLESS OTHERWISE SPECIFIED		CHECKED		
		APPROVED		
PARTY'S NAME PARAS ELECTRIC CORPORATION., BANGALORE		SCALE		3:1
		AREA mm ²		113.764
PARTY'S DRAWING No. AS PER SAMPLE		PERIMETER mm.		131.937
		WEIGHT kg/m		0.307
ALLOY & TEMPER HE9 WP		DRAWING No.		SECTION No.
		P-5901		-
DESCRIPTION MISCELLANEOUS SECTION		S1620		S1620
		25148		25148