

P-8000-1

25150

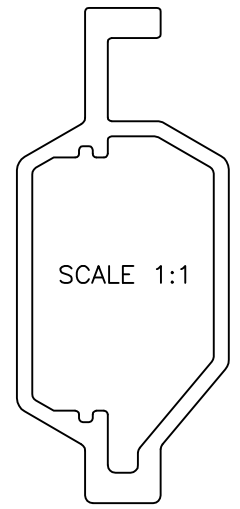
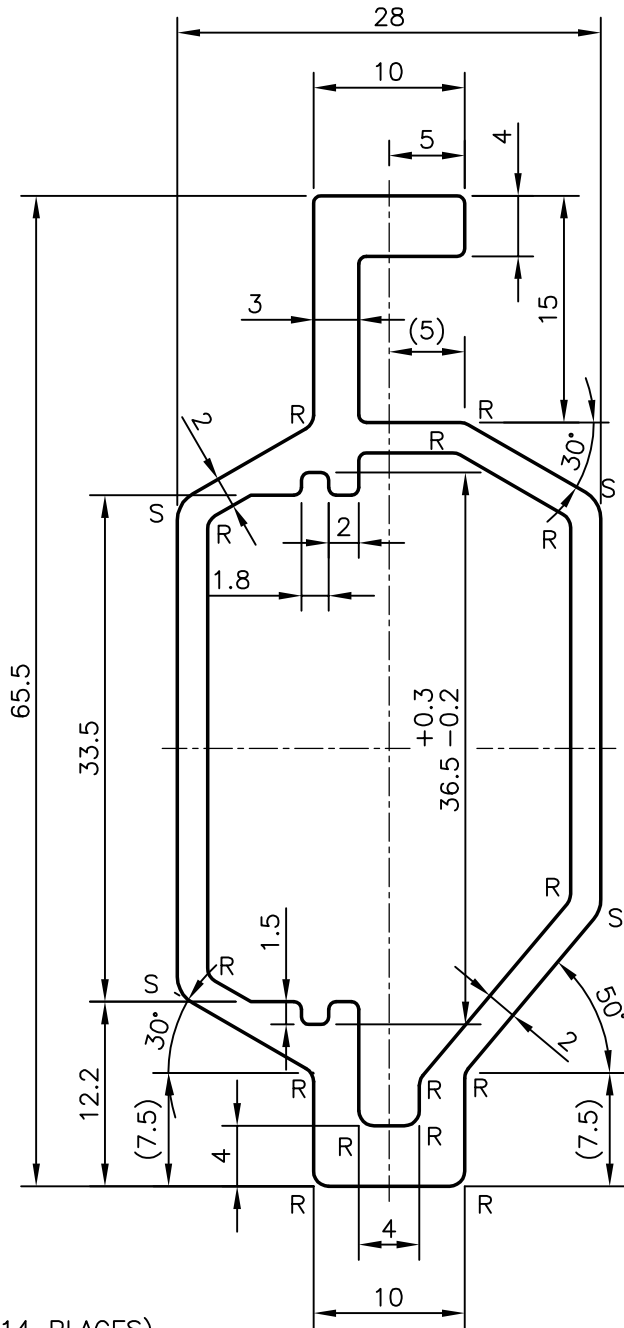

SCALE 1:1

R = R1.0 mm (14 PLACES)  
 S = R2.0 mm (4 PLACES)  
 UNSPECIFIED RADII R0.50 mm  
 UNSPECIFIED WALL THICKNESS = 2.0 MM



SYMBOL OF QUALITY  
 AN ISO 9001 COMPANY

**JINDAL ALUMINIUM LTD.**  
 BANGALORE-560073 (INDIA)

	NAME	DATE
DRAWN	PRASANNA.H	11-03-2008
CHECKED		
APPROVED		

1. ALL DIMENSIONS ARE IN mm.
2. ROUND OFF ALL SHARP CORNERS WITH 0.50 mm.
3. TOLERANCES WILL BE AS PER IS:6477-1983 UNLESS OTHERWISE SPECIFIED

SCALE	2:1
AREA mm <sup>2</sup>	379.821
PERIMETER mm.	180.971
WEIGHT kg/m	1.026

PARTY'S NAME ABB LTD.,-PROCESS AUTOMATION DIVISION  
 BANGALORE

PARTY'S DRAWING No. 1MRK000019-85/REV-A

ALLOY & TEMPER 6060 T6

DESCRIPTION MISC. SECTION

DRAWING No.	SECTION No.
P-8000-1	-
25150	25150