

P-6552-2

S1800

25153

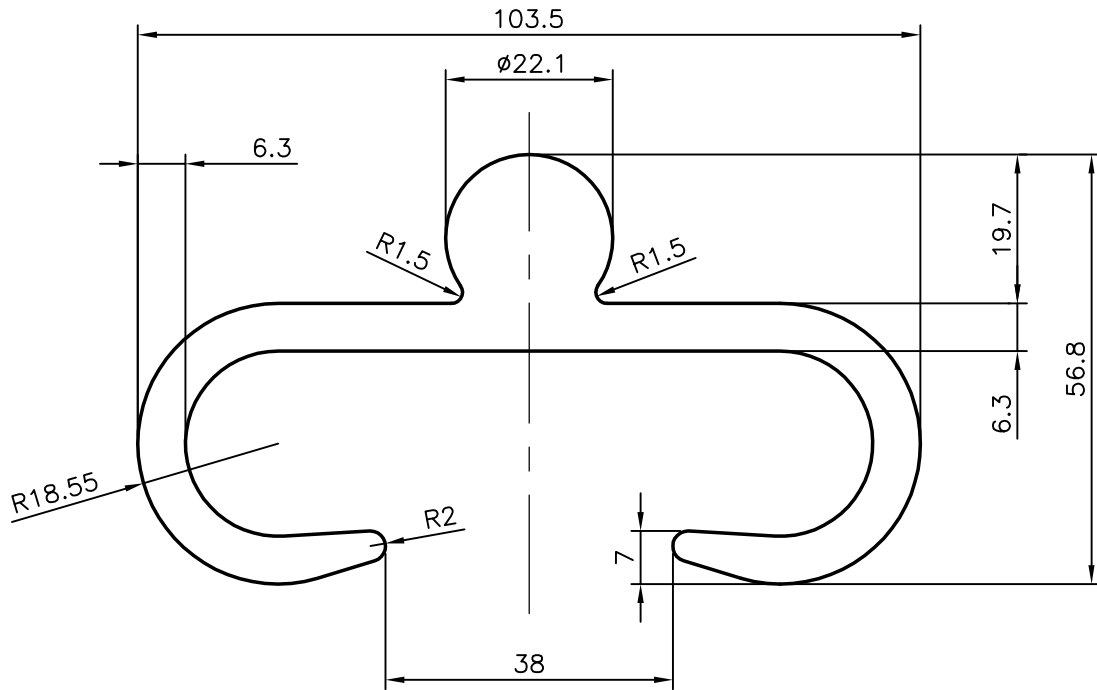

SYMBOL OF QUALITY  
AN ISO 9001 COMPANY

**JINDAL ALUMINIUM LTD.**  
BANGALORE-560073 (INDIA)

	NAME	DATE
DRAWN	J.P.KAUSHIK	14-07-2006
CHECKED		
APPROVED		

1. ALL DIMENSIONS ARE IN mm.
2. ROUND OFF ALL SHARP CORNERS WITH 0.40 mm.
3. TOLERANCES WILL BE AS PER IS:3965-1981 UNLESS OTHERWISE SPECIFIED

SCALE	1:1
AREA mm <sup>2</sup>	1540.055
PERIMETER mm.	422.575
WEIGHT kg/m	4.158

PARTY'S NAME	SUNLIGHT ELECTRICALS, BANGALORE
PARTY'S DRAWING No.	AS PER SAMPLE
ALLOY & TEMPER	6061 T6
DESCRIPTION	ELECTRICAL SECTION

DRAWING No.	SECTION No.
P-6552-2	-
S1800	S1800
25153	25153